

Installation instructions

Glass ceramic hob, Induction wok
Frameless, for flush installation



J226.123-2

10.9.08 ITH



The appliance should be installed by qualified personnel only. Each step must be carried out and checked in full in the order specified.

Validity

These installation instructions apply to the model: **226** (GK16TIWF / ETWI 6310)

General notes



If fitting in flammable material, the guidelines and standards for low voltage installations and for the fire protection must be strictly observed.

Identification plate

The identification plate is next to the connection plate.

- ▶ Affix the second identification plate (enclosed) in an accessible position behind the front of the fitted cabinet beneath the appliance.

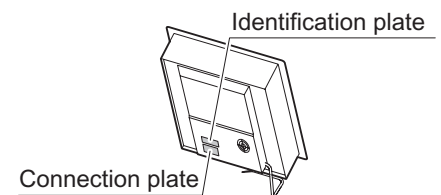

Installation accessories included

Designation	Article no.
Cementing-in instructions	J004.133
Sealing strip set	H6.2142
Wok pan, set Comprising wok pan, cover, rack, wok stand	H6.2596

Accessories

Designation	Article no.
Steel angle set Installation dimension 40	H6.2571
Instant adhesive for the installation of the steel angle Permabond F246, incl. Activator, 50 ml tube. From Silitech AG, 3008 Bern.	B11.502
Cement set Complete with cleaning agent, primer type 1105, cartridge with silicon adhesive, black with nozzle. Suitable for all absorbent worktop materials (wood and natural stones such as marble and granite).	86.3928.85
Special primer type 107 Suitable for non-absorbent worktop materials (not suitable for polyethylene, polypropylene or Teflon).	45.2771.76

Installation instructions

Glass ceramic hob, Induction wok
Frameless, for flush installation



J226.123-2

10.9.08 ITH

Electrical connections



Electrical connections must be carried out by trained electricians in accordance with the guidelines and standards for low voltage installations and the specifications of the local electricity supply companies.

A plug-in appliance may only be connected to a socket outlet with earthing contact, installed according to specifications. A mains isolating device with 3 mm contact opening should be provided in the house wiring system. Switches, plug and socket devices, circuit breakers and fusible cut-outs which are accessible after installation and which have all-poles switching are permissible as isolating devices. Effective earthing and separately installed neutral and earth conductors ensure safe and fault-free operation. After installation, live parts and cables with basic insulation must not be accessible. Old installations should always be checked.

- ▶ Information on the necessary mains voltage, type of current and fuse protection is to be obtained from the identification plate.
- ▶ The appliance is equipped with a mains cable that should be connected to a distribution box by the customer.

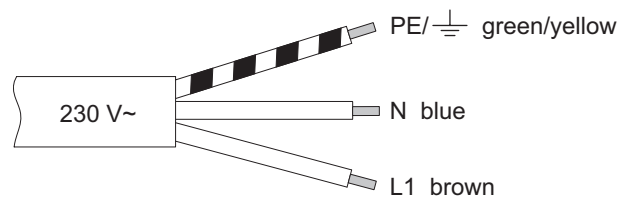
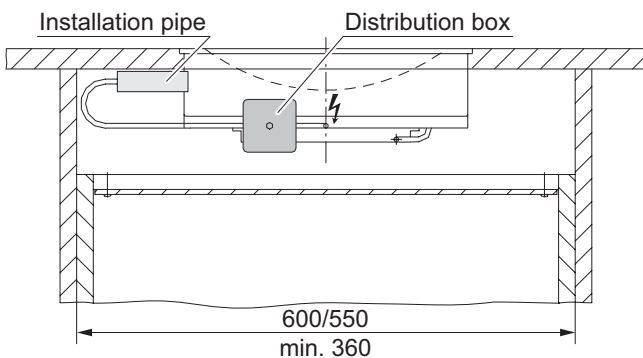

Error message U400



Incorrect connection:

A pole conductor was connected to the connecting terminal for neutral conductors.
Quickly disconnect the appliance from the mains!

Installation

Indications

- The worktop must be flat.
- In order to guarantee good ventilation, a space of at least 2 cm height is necessary beneath the appliance.
- The appliance is installed over an intermediate base which must be removable from below.
Safety requirement: Removable with tools.
- Width of material between cut-outs for adjacent appliances in stone worktops:
The material width is determined by the producer of the stone worktop. The minimum material width of 40–60 mm can vary according to the property of the stone, or it can be reinforced below.

Installation instructions

Glass ceramic hob, Induction wok
Frameless, for flush installation



J226.123-2

10.9.08 ITH

Installing

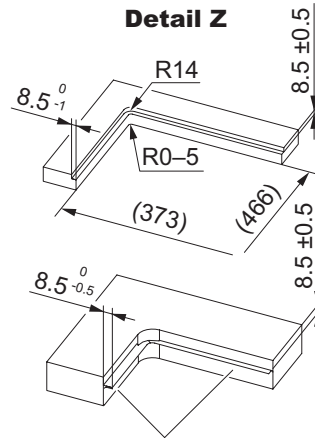
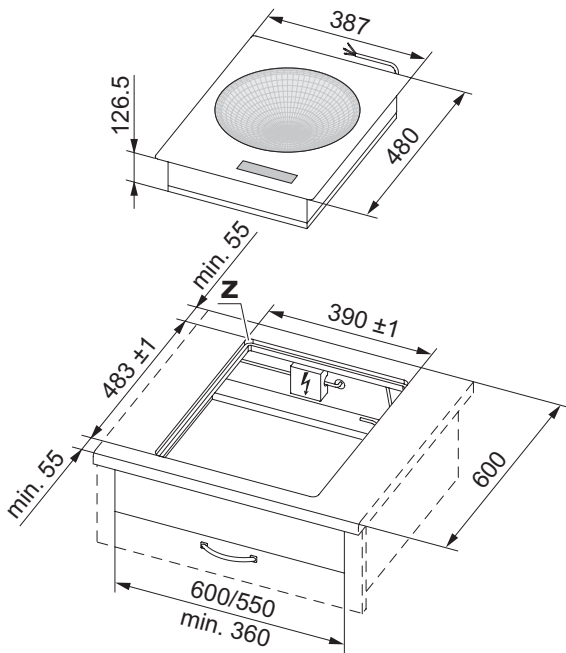

Steel angle bonded or screw mounted
(for adhesive see «Accessories»)

1. Create the cut-out accurately.
 - The mounting surface can be recessed by installing wood or stone bars or produced using the steel angle set (see «Accessories»).



Access to the appliance from below must be guaranteed over the entire cut-out surface. For servicing, the induction generator with the mounting plate can be removed from below. The covers to prevent accidental contact with live parts must be removable by unscrewing.

2. Prepare the cut-out and the appliance according to the information in the accompanying cementing-in instructions.



To prevent projecting, mount the ceramic plate displaced downwards by 0.1 mm with respect to the worktop.

3. Carefully cement the appliance in place and allow the silicon cement joints to dry for at least 24 hours.
4. Where necessary establish the mains supply connection before inserting the appliance.

Symmetric to the niche width

