

## Installation instructions

Range hood DF-SLG8 / DF-SLG9

Built-in range hood

Operating modes: extracted air / recirculation air



J378.113-0

30.3.09 ITH



The appliance should be installed by qualified personnel only. Each step must be carried out and checked in full in the order specified.

## Validity

These installation instructions apply to the models:

**378** (DF-SLG8, construction width 82.5 cm)

**385** (DF-SLG9, construction width 90 cm)

## General notes



With the simultaneous operation of firing (e.g. wood, gas, oil or coal-fired heating systems), safe operation is only possible providing a room negative pressure of 4 Pa (0.04 mbar) is not exceeded at the location of the appliance. Risk of toxic fumes! An adequate flow of fresh air must be guaranteed, e.g. via non-closable openings in doors and windows and combined with ventilation wall bricks for incoming and exhaust air or by other technical means.



If the appliance is installed over hobs, each cooking zone must be fitted with an ignition fuse and the minimum distances (see «Dimensions») must be adhered to.



Efficient repairs can only be guaranteed if it is possible to disconnect the appliance at any time without causing any damage.

## Identification plate

► Remove grease filter. The identification plate is on the inside of the appliance.

## Supplied installation accessories

All fixing elements are contained in the scope of delivery.

## Extraction mode



The extracted air must not be fed into a chimney which is used for exhausting fumes from appliances burning gas or other fuels.

Always observe the fire regulations.

## Recirculation mode

The following possibilities exist if the appliance is to be used in recirculation mode:

– **Using an active carbon filter mounted directly in the appliance** (see J415.48)



The cross-section area (air discharge surface area) of the ventilation grille must be at least 200 cm<sup>2</sup>.

In this application the extracted air flows through the exhaust air connection, from where it is blown out and is then blown back into the room through a ventilation grille in the ceiling cover.

– **Using an air recycling cassette LRC1** (see J590.50)

In this application the active carbon filter is installed in the air recycling cassette. The extracted air flows through the exhaust air connection and an exhaust air conduit, into the cassette and is blown back into the room through the air discharge grille.

## Electrical connections



Electrical connections must be carried out by trained electricians in accordance with the guidelines and standards for low voltage installations and the specifications of the local electricity supply companies.

A plug-in appliance may only be connected to a socket outlet with earthing contact, installed according to specifications. An all-pole mains isolating device with 3 mm contact opening should be provided in the house wiring system. Switches, plug and socket devices, circuit breakers and fusible cut-outs which are accessible after installation and which have all-poles switching are permissible as isolating devices. Effective earthing and separately installed neutral and earth conductors ensure safe and fault-free operation. After installation, live parts and cables with basic insulation must not be accessible. Old installations should always be checked.

► Information on the necessary mains voltage, type of current and fuse protection can be taken from the identification plate.



# Installation instructions

Range hood DF-SLG8 / DF-SLG9

Built-in range hood

Operating modes: extracted air / recirculation air



J378.113-0

30.3.09 ITH

## Installation

### Indications

- Avoid routing the exhaust air pipeline to the side.
- All plastering, plasterboarding, wall papering or painting work is to be carried out prior to the installation.

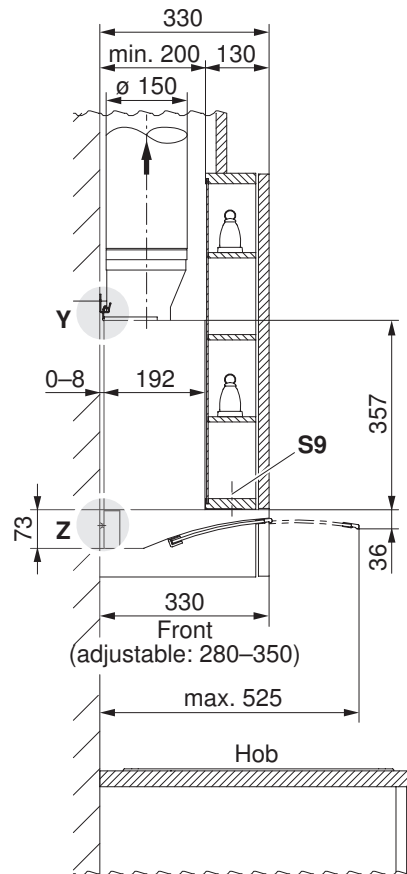
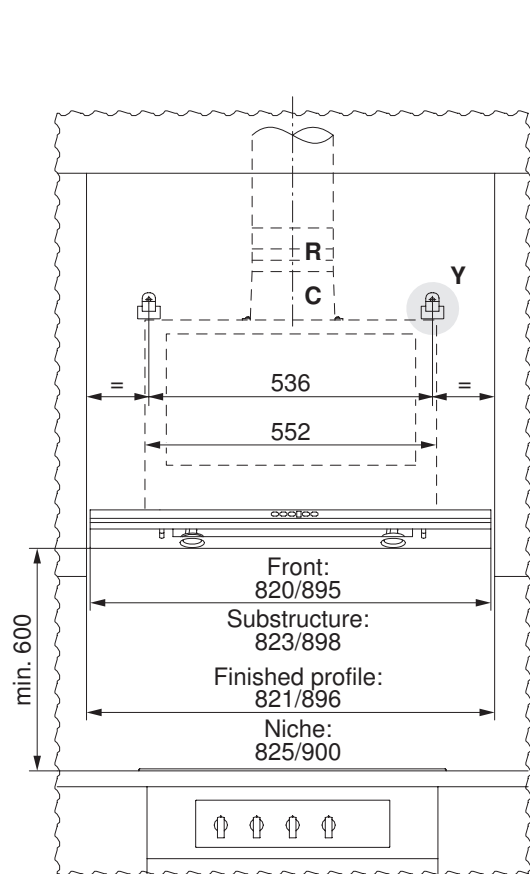

Detail Y

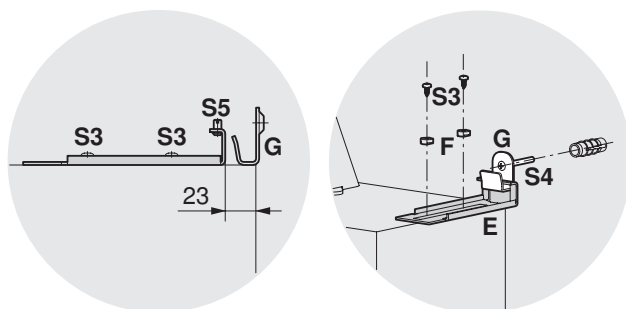

Detail Z

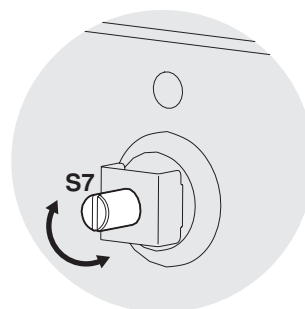

## Installation instructions

Range hood DF-SLG8 / DF-SLG9

Built-in range hood

Operating modes: extracted air / recirculation air



J378.113-0

30.3.09 ITH

### Installation

1. Mount a suitable finished profile **A** to the fan box **B** with screws **S1** ( $\varnothing 3 \times 13$  mm).
2. Mount exhaust air connection **C** and seal **D** to the fan box **B** with screws **S2** ( $\varnothing 3,5 \times 9$  mm).
3. On both sides, mount suspension bracket **E** to the fan box **B** with spacers **F** and screws **S3** ( $\varnothing 3,5 \times 13$  mm) and set a distance of 23 mm from rear panel (see **Detail Y**). Fit screws **S3** only finger-tight.
4. Drill holes for screws **S4** in rear panel. Insert plugs ( $\varnothing 8$  mm) and fix retainer hook **G** with screws **S4** ( $\varnothing 5 \times 45$  mm) (see **Detail Y**).
5. Push fan box **B** in niche until suspension brackets **E** can be pushed over retainer hook **G**. Tighten screws **S3**.
6. Set distance to rear panel with the two adjuster screws **S7** (see **Detail Z**).  
Set horizontal position with the two adjuster screws **S5** (see **Detail Y**).
7. Check correct position of cover strip **H**. Take care not to trap it on assembly!
8. Place substructure **J** on the fan box **B** (rail profile left/right) and push it carefully over finished profile **A**. Maintain a minimum distance of 2 mm between finished profile **A** and wall unit to ensure that the substructure can be pushed smoothly in place.
9. Set the wall unit depth (pull substructure **J** forward or push it back) and tighten screw **S8** left/right.
10. Establish electrical connections **K** (lighting) and **L** (control unit); note the coding.
11. Screw range hood additionally to the wall unit with screws **S9** ( $\varnothing 3 \times 13$  mm).
12. Establish electrical connection (see section «Electrical connections»).
13. Fix metal ring **R** ( $\varnothing 150$  mm) to exhaust air connection and mount the venting hose. A reduction connector can be used where required.

