



Operating instruction

Adora N fully integrated

Dishwasher

1 Safety precautions



Read the operating instructions before using the appliance for the first time.

1.1 General safety precautions

- This appliance can be used by children aged 8 and above and by persons with reduced physical, sensory or mental capabilities, or lack of experience and/or knowledge, provided they are supervised or have been instructed on the safe use of the appliance and have understood the hazards involved. Children must not play with the appliance. Cleaning and user maintenance shall not be undertaken by children without supervision.
- If an appliance is not equipped with a mains cable and a plug or other means for disconnecting from the mains with a contact opening on each pole complying with the conditions of overvoltage category III for full isolation, an isolating device must be incorporated into the permanently installed electrical in-

stallation in accordance with the installation regulations.

- If the mains cable of this appliance is damaged, it must be replaced by the manufacturer or its Customer Services or a similarly qualified person in order to avoid hazard.

1.2 Appliance-specific safety precautions

- Never use a steam cleaner to clean the appliance.
- If the appliance is installed on a carpeted floor ensure that the ventilation openings on the base of the appliance are not obstructed.
- Only leave the appliance door open in the at-rest position. An open appliance door poses a danger of tripping or injury. Do not sit or rest on the appliance door or use it as a storage surface.
- CAUTION: Knives and other items with sharp points must be placed with the point downwards or placed horizontally in the basket.
- CAUTION: Do not drop or insert knives, forks or other

sharp items in the opening of the door lock.

- No detergent must enter the opening of the door lock. This can cause the door lock to malfunction.
- The appliance is only suitable for washing household dishes and cutlery with water and standard dishwasher detergent. The appliance is for use in the home and for the intended purpose only. No liability is assumed for any damage caused by improper or incorrect use.
- Capacity: 13 international place settings
- This appliance is designed to be used for household and similar purposes such as: staff kitchens in shops, offices and other commercial premises; agricultural properties; by customers in hotels, motels and other residential facilities; in bed-and-breakfast hotels.

1.3 Correct use

- Any repairs, modifications or manipulations to the appliance, especially any electrically live parts, may only be carried out by the manufacturer, its Customer Services or a similarly qualified person. Repairs if carried out incorrectly may cause serious injury, damage to the appliance and fittings, as well as affect the functioning of the appliance. If the appliance is not working properly or in case of a repair order, follow the instructions given in the «Service & Support» section. Please contact our Customer Services if necessary.

1.4 Instructions for use



Switching off the power to the appliance disables the built-in overflow protection system.

Dishwasher detergents are strongly alkaline. They can be extremely dangerous if swallowed. Avoid contact with the skin and eyes and keep children away from the dishwasher when the door is open. Check that the detergent receptacle is empty after completion of the wash cycle.

- If the appliance is visibly damaged, do not use it. Contact our Customer Services.
- If the appliance is not operating properly, disconnect it from the power supply immediately.
- Use original spare parts only.
- Retain these operating instructions for future reference.
- Avoid opening the appliance door unnecessarily during operation. The dishes and water may be hot – scalding hazard! The steam that escapes can dam-

age wood combination fascias. Spectacles can steam up, impairing your vision.

- Do not wash objects that are soiled with inflammable or corrosive solvent, paint, wax, chemicals (acids or alkaline solutions) or iron chippings or that can shed fibres in the appliance.
- Packaging material, e.g. plastic film and polystyrene, can be dangerous for children. Danger of suffocation! Keep packaging material away from children.

1.5 Transport and installation

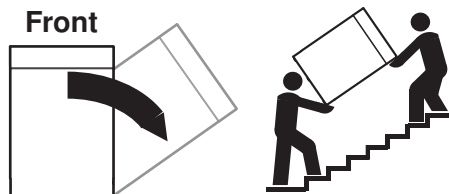

Do not tilt more than 90° to the right!

Transport the appliance in an upright position only! Transporting it in any other position will result in damage to the appliance! When carried carefully without being shaken, the appliance may be tilted a maximum of 90° to the left (viewed from the front).

1.6 How to avoid damaging the appliance

- Before closing the appliance door and starting a programme ensure that there are no foreign objects (e.g. nails or paper clips) or pets in the appliance. Foreign objects can damage parts of the appliance as well as the dishes.
- Never fill the rinse agent reservoir or the regeneration salt reservoir with detergent! If this were to happen, however, do not operate the appliance under any circumstances, as this could cause expensive damage to it. Call Customer Services.
- Do not lean on any part of the appliance – risk of accident!
- Turn off the water tap during longer absences.
- The appliance must be connected to the mains supply to ensure appliance protection (overflow protection, among other things).

1.7 Using for the first time



The appliance must be installed and connected to the electricity supply by a qualified fitter/electrician in accordance with the separate installation instructions.

Before operating the newly installed appliance for the first time, the following steps should be taken:

Before using for the first time

- ▶ Switch on the power and turn on the water tap.
- ▶ Set (see page 23) the water hardness.
- ▶ Fill the salt reservoir with approximately 1.0 l water and 1 kg regeneration salt. Wipe away any excess salt on the edge of the salt reservoir.
- ▶ Fill the rinse agent reservoir with rinse agent.
- ▶ Run the  programme without dishes to protect the appliance from corrosion from any excess salt and to remove traces of grease left behind from the manufacturing process.

The **S** refill indicator can flash during the first few wash cycles. **S** goes out when the salt concentration in the reservoir is evenly distributed.

1.8 Notes on using the operating instructions

Graphical operating instructions can be downloaded on the internet from www.vzug.ch.

Symbols used



Denotes important safety precautions.

Failure to observe said precautions can result in injury or in damage to the appliance or fittings!

Validity

The product family (model number) corresponds to the first alphanumeric on the identification plate. These operating instructions apply to:

Model	Type	Product range
Adora 60 N (EURO 60)	GS60NZVi	41075

Variations depending on the model are noted in the text.

Modifications

Text, diagrams and data correspond to the technical standard of the appliance at the time these operating instructions went to press. The right to make technical modifications for the purpose of the further development of the appliances is reserved.

Contents

1	Safety precautions	2		
2	Appliance description	7		
2.1	Construction.....	7		
2.2	Operating and display elements.....	8		
3	Programme overview	9		
3.1	Programme.....	9		
3.2	Additional functions.....	9		
4	Operation	10		
4.1	Preparing the appliance.....	10		
4.2	Dish washing tips.....	10		
4.3	Loading tips for the upper basket.....	11		
4.4	Loading tips for the lower basket.....	13		
4.5	Detergent.....	16		
4.6	Selecting a programme.....	18		
4.7	Delayed start.....	19		
4.8	Interrupting a programme.....	20		
4.9	Aborting a programme before time.....	20		
4.10	End of programme.....	21		
5	User settings	22		
5.1	Overview of user settings.....	22		
5.2	Changing user settings.....	22		
5.3	Acoustic signal.....	23		
5.4	All in 1.....	23		
5.5	Water hardness.....	23		
5.6	Rinse agent dosage.....	23		
5.7	DryPlus.....	24		
5.8	RinsePlus.....	24		
5.9	Hot water connection.....	24		
5.10	Automatic standby.....	24		
5.11	Factory setting.....	24		
6	Care and maintenance	25		
6.1	Cleaning the interior and exterior.....	25		
6.2	Cleaning the spray arms.....	25		
6.3	Cleaning the filter system.....	26		
6.4	Refilling with regeneration salt.....	26		
6.5	Filling with rinse agent.....	27		
7	Trouble-shooting	28		
7.1	Error messages.....	28		
7.2	Other possible problems.....	30		
7.3	Unsatisfactory washing results.....	30		
7.4	In the event of a power failure.....	31		
8	Accessories and spare parts	32		
9	Technical data	34		
9.1	Consumption data.....	35		
9.2	Note for testing institutes.....	35		
9.3	Noise measurement.....	35		
10	Disposal	36		
11	Notes	37		

2 Appliance description

2.1 Construction

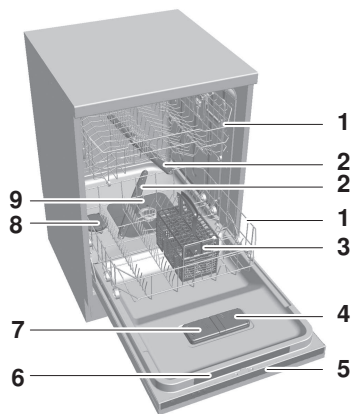

- 1 Baskets
- 2 Spray arms
- 3 Cutlery basket
- 4 Rinse agent reservoir
- 5 Operating and display elements *
- 6 Quick operating instructions
- 7 Detergent dispenser
- 8 Salt reservoir
- 9 Filter system

Integrated appliances

(operating elements are located on the outside of the appliance door):

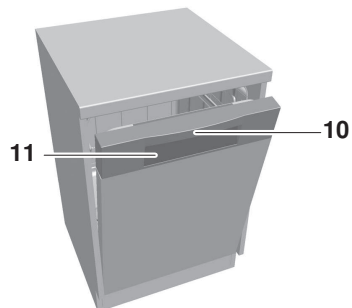

- 10 Door handle
- 11 Operating and display elements

Fully integrated and design integrated appliances

(operating elements are located on the inside of the appliance door):

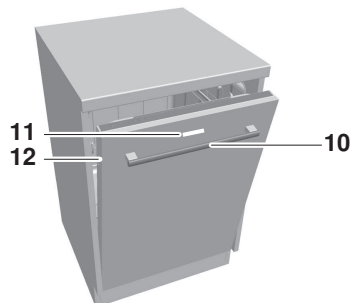

- 10 Door handle
- 11 Operation indicator on glass panel *
- 12 Function light *

* Depending on model

2.2 Operating and display elements

Integrated appliances:

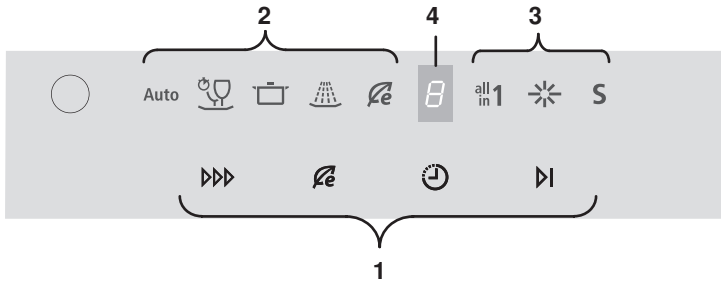

Fully integrated and design integrated appliances:

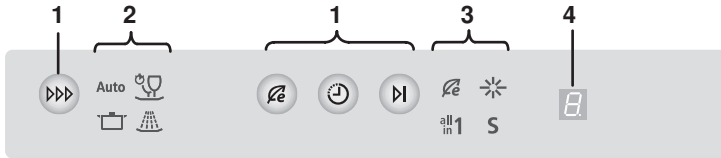

<p>1 Buttons</p> <p>▶▶▶ Programme selection</p> <p>🌿 Eco programme</p> <p>🕒 Delayed start</p> <p>▶ End of programme</p>	<p>2 Programme symbols</p> <p>Auto Automatic</p> <p>🍷 Quick wash/ Glass care</p> <p>🧺 Intensive</p> <p>🚿 Pre-rinsing</p>	<p>3 Additional function symbols /Indicator symbols</p> <p>🌿 Energy saving</p> <p>🌟 Rinse agent refill indicator</p> <p>all in 1 «All in 1» detergent</p> <p>S Salt refill indicator</p>
<p>4 Display</p> <ul style="list-style-type: none"> Delayed start Error messages 	<p>Acoustic signal (depending on model)</p> <p>An acoustic signal is emitted at the end of the programme and in the event of a malfunction.</p>	<p>Function light (depending on model)</p> <ul style="list-style-type: none"> Illuminates during the programme sequence. Flashes during the final drying phase.

3 Programme overview

3.1 Programme

Programme time and energy consumption can be reduced by selecting the  additional function.



Eco programme: The most efficient programme in terms of water and energy consumption for normally dirty dishes (declaration programme).

Auto

Automatic: Optimum cleaning with minimal water and energy consumption. Not for burnt-on or dried leftovers.



Quick wash/Glass care: For slightly dirty dishes such as drinks glasses or coffee cups and saucers. Not suitable for slowly dissolving tabs.



Intensive: For very dirty dishes, particularly with starchy leftovers (mashed potato, rice etc.).



Pre-rinsing: Prevents dirt drying on if the wash programme is not going to be started until later.

3.2 Additional functions



Energy saving: The rinsing temperature is reduced by 5 °C for around 10 % less energy consumption Gentle on glasses.



Delayed start: Allows you to wash during off-peak hours (e.g. at off-peak electricity rates). A delayed start of between 1 and 9 hours can be set.

4 Operation

4.1 Preparing the appliance

- ▶ Remove any coarse or hard pieces of food or foreign objects (such as toothpicks) left on the dishes.
- ▶ Load the baskets. After loading, check that the spray arms can turn freely.

4.2 Dish washing tips

General notes

- Do not overload the baskets.
- Dishes, pots and pans with heavily burned-on food debris stuck to them should be soaked in water first.
- Load beverage and food containers such as cups, glasses, pots, etc. with the opening facing downwards so that the water can drain off.
- When loading, ensure glasses do not touch so as to prevent damage and water spots.
- When cleaning range hood grease filters, select the  programme and use the maximum amount of detergent.

Dishes

Not all table- and kitchenware are dishwasher safe.

- Clean wooden or plastic parts that are sensitive to damage from heat and detergent suds by hand.
- Pottery has a tendency to crack or chip.
- The printing on glass and porcelain is hard-wearing only to a point and eventually over time can wear off.
- Glassware, depending on the type and the detergent being used, can become cloudy. Check with your glassware supplier as to whether your glassware is dishwasher safe.
- Stress and tension in thick cut crystal glasses and dishes can cause cracking.
- Do not wash dishes with adhesive labels on them. Adhesive labels can come off and clog up the filter system.
- Objects made of silver, copper and tin tend to discolour, turning brown or black.
- Spots tend to form on aluminium. Wash aluminium separately or by hand.

4.3 Loading tips for the upper basket

- ▶ Arrange smaller items such as saucers, glasses, cups and dishes.
- ▶ If using the fold-down racks **1**, stagger the items.
- ▶ Rest glasses on the fold-down glass holder **2**.

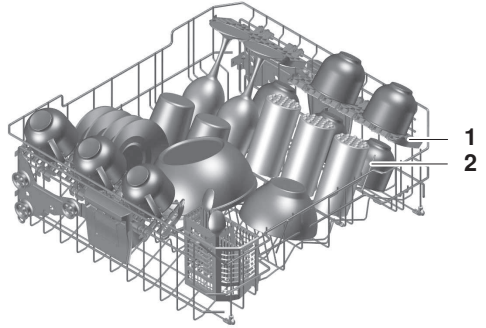

Glass holder

Particularly suitable for tall glasses.

- ▶ Push the glass holders **1** gently down or, alternatively, pull them up until they engage.

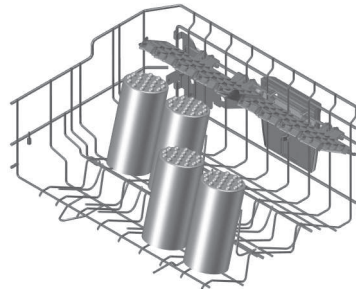
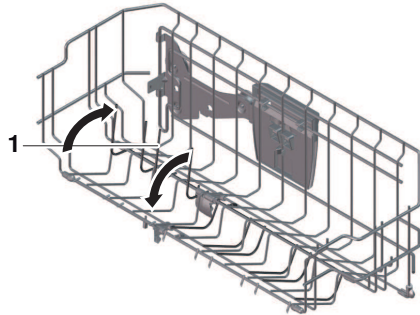

Easy prongs

For placing drinking glasses, baby bottles, vases and carafes anywhere in the basket.

- ▶ Put easy prong **1** over basket prongs.
- ▶ Use 2 easy prongs for wider vessels.

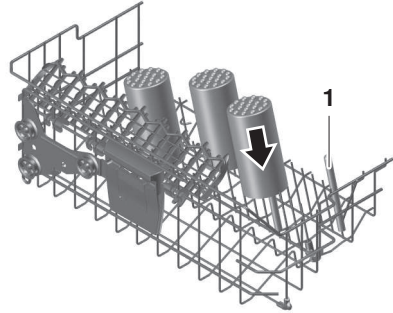

Racks

The racks **1** can also be used as glass holders. Remove the racks to accommodate tall glasses.

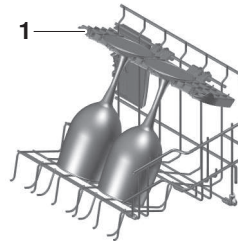

Dismantling/Adjusting the height of the racks

Push the rack **1** up by the hooks **2**.

Push the rack inward and then out.

- ▶ Hook the rack in the higher position **3**, if required.

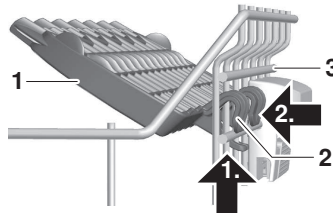

Adjusting the upper basket

The height of the upper basket can be adjusted by around 2–4 cm (depending on model). It can be inclined in various ways.

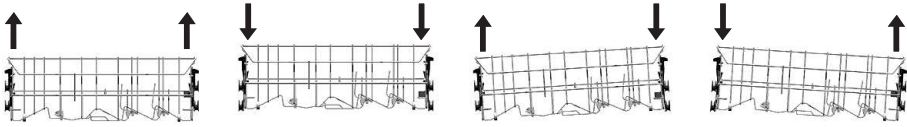

- ▶ To raise: Hold the upper basket at the sides by the grips **1** and raise it into the position required.

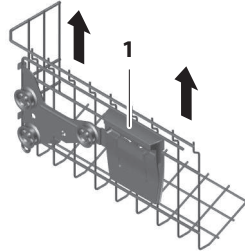

- ▶ To lower: Hold the upper basket at the sides by the grips **1**.
- ▶ Raise the upper basket slightly and press the button **2** at the same time. The locking device is released.
- ▶ Lower the upper basket into the position required, release the button and engage the basket.
- ▶ Put plastic bowls in the upper basket.

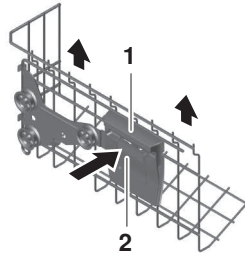

4.4 Loading tips for the lower basket

- ▶ Load larger items such as plates, bowls, platters, pots and pans.
- ▶ Load wide items (soup plates, lids, etc.) at the back on the right.

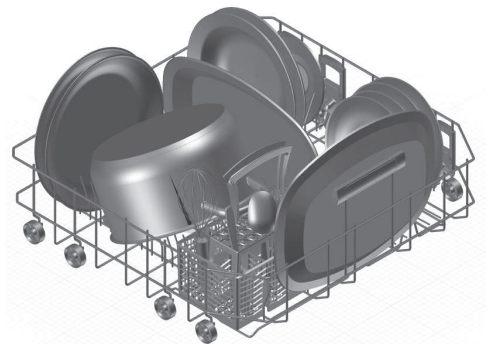

Easy prongs

For placing drinking glasses, baby bottles, vases and carafes anywhere in the basket.

- ▶ Put easy prong **1** over basket prongs.
- ▶ Use 2 easy prongs for wider vessels.

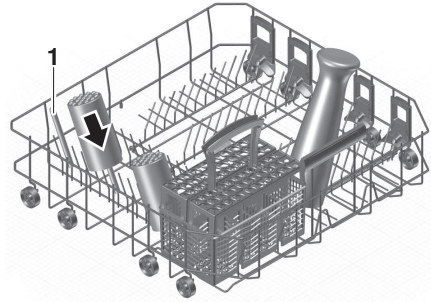

Cleaning baking and steaming trays

The upper basket has to be removed for larger trays.

- ▶ Slide the upper basket out as far as possible.
- ▶ Remove the basket safety lock **2** by pushing it upwards.
- ▶ Pull the upper basket out of its guides.
- ▶ Load baking trays, using easy prongs for greater stability.

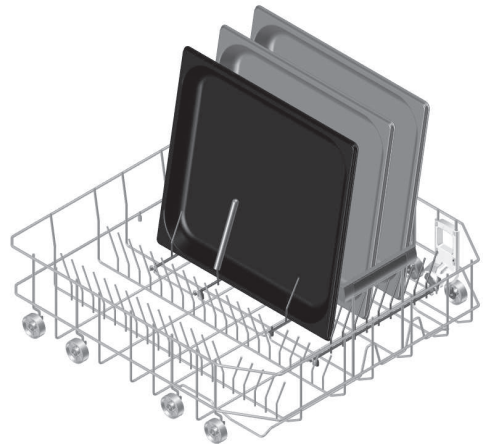
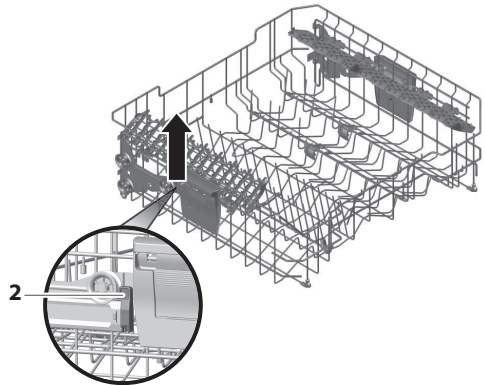

- ▶ When the upper basket is put back, the basket safety lock **2** must be returned to the locking position.

Cutlery basket



To avoid injury, place knives and cutlery with sharp edges or points into the cutlery basket in such a way that they do not stick out (points facing downwards).

Do not drop or insert knives, forks or other sharp items in the opening of the door lock. Risk of damage to the appliance!

Knives and cutlery with sharp edges or points may also be placed horizontally in the upper basket.

- ▶ Place the cutlery basket over the folded-down prongs anywhere in the basket.
- ▶ Distribute cutlery loosely in the basket, with handles pointing down (except for knives and the like). Spoons should not be stuck together.
- ▶ To prevent items of cutlery sticking together, water spots during drying, and smaller items slipping through the basket, put the inserts **1** supplied on the cutlery basket.

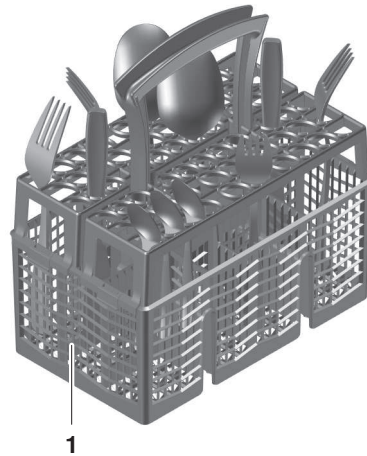

When closing the appliance door, ensure no items of cutlery are sticking out of the tub or are trapped. The leak tightness of the appliance cannot otherwise be assured.

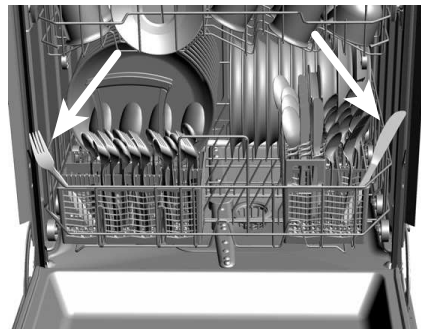

4.5 Detergent

Choice of detergent



Never use washing-up liquid. Heavy foaming can cause malfunctions. Strictly observe the dosage instructions printed on the packaging and contact the detergent manufacturer if you have any questions. Using too high or low a dosage can cause damage to the appliance.

- ▶ Only use detergent specially formulated for dishwashers. Tabs may not dissolve properly at a wash temperature of below 55 °C, affecting the cleaning performance of the appliance.

Combination cleaning products (*all in 1* tabs/powder)

Continue to use regeneration salt and rinse agent for a good cleaning performance.

- ▶ Set «All in 1» to  in the user settings. The programmes and displays are adapted to suit the detergent.



When the **S or  refill indicators flash, continue to refill with regeneration salt or rinse agent.**

- ▶ If, after washing and drying, the results are not satisfactory, use conventional cleaning products. Set «All in 1» to  in the user settings. For complaints, contact the detergent manufacturer.

Adding the detergent



No detergent must enter the opening of the door lock. This can cause the door lock to malfunction.

Powder

- ▶ Open the detergent dispenser by pushing the release catch in the direction of the arrow.
- ▶ Add the detergent to the detergent compartment. For dosage, follow the detergent manufacturer's instructions.
- ▶ Observe the «20 and 30 ml» level marks **1**.
- ▶ For heavier soiling, add approximately 1 teaspoon of detergent to the pre-rinsing compartment **2**.
- ▶ Close the cover.

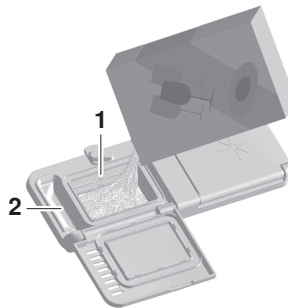
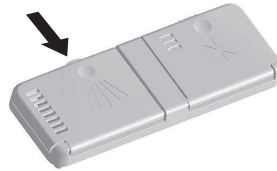

Tabs

- ▶ Place the tab **3** flat in the detergent compartment.

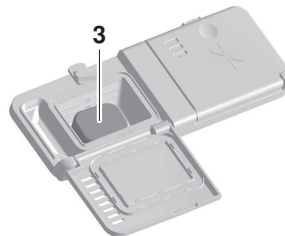

4.6 Selecting a programme



- ▶ Press the button repeatedly until the required programme symbol flashes.
- ▶ Select any additional function(s), if required.
- ▶ Close the appliance door.

Integrated appliances: The programme starts in 15 seconds.

Fully integrated and design integrated appliances: The programme starts immediately. The function light illuminates (depending on model).

If the appliance door is not closed within 15 seconds, all entries, symbols and the display are cleared; a 2× acoustic signal is also emitted (depending on model). The programme must be selected again. Press the  button at any time to cancel the programme selected.

NOTE! Integrated appliances can also be operated with the appliance door closed.



Selecting the Eco programme



- ▶ With the appliance switched off, press the button.
- ▶ Close the appliance door.

The programme starts.

Selecting additional function

Additional functions can be selected within 15 seconds of selecting a programme. e.g.

- ▶ Press the required additional function button. The corresponding symbol illuminates.



- ▶ Close the appliance door.

The programme starts.



NOTE! The  additional function cannot be selected with the  programme.

Saving additional functions

When an additional function is saved, it is automatically active during programme selection.

- ▶ Select the programme.
- ▶ Press the additional function button for 5 seconds. The selection is saved.
- ▶ To cancel the additional function, press the additional function button for 5 seconds.

The symbol flashes briefly and an acoustic signal sounds (depending on the model) to confirm that the additional function has been saved or deselected.

4.7 Delayed start

The delayed start allows you to wash during off-peak hours (e.g. at off-peak electricity rates). It can be set within 15 seconds of selecting a programme. A delayed start of between 1 and 9 hours can be set.

Setting



- ▶ Select a programme.
- ▶ Repeatedly press or hold down the button until the required delayed start duration appears in the display.
- ▶ Close the appliance door.
The display and symbols go dark *. The countdown to the set delayed start begins. When the delayed start duration is up, the programme selected starts automatically. No acoustic signal is emitted at the end of the programme.

Dishes can be loaded at any time during the delayed start.

* Depending on model

Cancelling a delayed start



- ▶ Open the appliance door.
- ▶ Repeatedly press or hold down the button until the delayed start is cleared.
- ▶ Close the appliance door.
The programme starts.

4.8 Interrupting a programme



The dishes and water may be hot. Scalding hazard!



- ▶ **Integrated appliances:** First press the button.
The programme is interrupted for 5 seconds.

- ▶ Carefully open the appliance door.

The programme symbol flashes.

At higher water temperatures, noise from the pump switching on and off up to 5 times with short pauses in between may be heard after the appliance door is closed. During this phase, temperature equalization takes place.

- ▶ **Fully and design-integrated appliances:** Carefully open the appliance door.
This interrupts the programme. The programme symbol flashes.
At higher water temperatures, noise from the pump switching on and off up to 5 times with short pauses in between may be heard after the appliance door is closed. During this phase, temperature equalization takes place.

4.9 Aborting a programme before time



The dishes and water may be hot. Scalding hazard!



- ▶ **Integrated appliances:** Press the button first.
The programme is interrupted for 5 seconds.

- ▶ Open the appliance door carefully.
The programme symbol flashes.

- ▶ **Fully integrated and design integrated appliances:** Open the appliance door carefully.
This interrupts the programme.
The programme symbol flashes.



- ▶ **All appliances:** Depress the button for 2 seconds.
The water is pumped off. The following appears in the display:

A 5× acoustic signal is emitted *. The display and symbols go out.

* Depending on model

4.10 End of programme

A 5x acoustic signal is emitted at the end of the programme *.

If the appliance door remains closed, final drying starts:

Integrated appliances: The symbols remain illuminated for up to 90 minutes.

Fully integrated and design integrated appliances: The operation indicator or function light flashes for up to 90 minutes *.

After final drying, 3 long acoustic signals are emitted *.

* Depending on model



For a better drying result, the appliance door should not be opened until a long acoustic signal is emitted and the operation indicator* goes out. After the final drying phase, the appliance enters the energy-saving stand-by mode. Alternatively open the door for supporting the drying result.

For optimum drying results, unload the appliance after the final drying phase is finished. When the final drying phase has finished, all the displays go out and the appliance enters the energy-saving stand-by mode.

Unloading

- ▶ Unload the appliance. Unload the lower basket first.
- ▶ Periodically check the filter system and clean if necessary.

5 User settings

5.1 Overview of user settings

Hold the **▶|** button depressed for 5 seconds.

E			
🔊	Acoustic signal *	<input type="checkbox"/> Off <input type="checkbox"/> Low** <input type="checkbox"/> High	
all in 1	All in 1	<input type="checkbox"/> Off** <input type="checkbox"/> On	
S	Water hardness	<input type="checkbox"/> Off <input type="checkbox"/> Level 1 <input type="checkbox"/> Level 5** <input type="checkbox"/> Level 9	
✳	Rinse agent dosage	<input type="checkbox"/> Off <input type="checkbox"/> Level 1 <input type="checkbox"/> Level 4** <input type="checkbox"/> Level 9	
🔊 + ✳	Drying Plus	<input type="checkbox"/> Off** <input type="checkbox"/> On	
🔊 + all in 1	Rinsing Plus	<input type="checkbox"/> Off** <input type="checkbox"/> On	
✳ + S	Hot water connection	<input type="checkbox"/> Off** <input type="checkbox"/> On	
🔊 + S	Automatic stand-by	<input type="checkbox"/> Off <input type="checkbox"/> On**	
all in 1 + S	Factory setting	<input type="checkbox"/> No** <input type="checkbox"/> Yes	

* Depending on model
 ** Factory setting

5.2 Changing user settings

- ▶ Hold the **▶|** button depressed for about 5 seconds until the following appears in the display: **E**
- ▶ Press the **▶|** button repeatedly until the required user setting (symbol) illuminates.
- ▶ Press the **▶▶▶** button to change the user setting.
- ▶ To save the changes, press the **▶|** button repeatedly until the display goes out.

If no button is pressed within the next 15 seconds, the user settings are saved and the display goes out.



5.3 Acoustic signal

Only present on fully and design-integrated appliances.

Display on operating panel: 

Factory setting: 

Possible settings:

-  Off
-  Low
-  High

The acoustic signal can be turned off or on. In the event of a malfunction, an acoustic signal is emitted even in the off mode.

5.4 All in 1

Display on operating panel: 



Factory setting: 

Possible settings:

-  Off
-  On

The programmes must be adapted for use with detergent with integrated salt and rinse agent function. The duration of very short programmes is extended because such detergent takes longer to dissolve.



 products are not suitable for all degrees of water hardness. Follow the detergent manufacturer's instructions. When the **S or  refill indicators flash, continue to refill with regeneration salt or rinse agent.**

5.5 Water hardness

Display on panel: **S**

Factory setting: 

Possible settings:

-  Off
-  Level 1–9

The water hardness setting can be changed to suit local conditions. Contact your local water authority for the relevant information.

Water hardness levels

Level	0	1	2	3	4	5	6	7	8	9
°fH	0–5	6–10	11–15	16–20	21–25	26–30	31–40	41–50	51–70	71–120
°dH	0–3	4–6	7–9	10–12	13–14	15–16	17–22	23–27	28–38	39–65

5.6 Rinse agent dosage

Display on operating panel: 



Factory setting 

Possible settings:

-  Off
-  Level 1–9

If the drying result is unsatisfactory, the dosage can be either turned off or set to one of 9 levels.



5.7 DryPlus

Display on operating panel:  and 
Factory setting: 
Possible settings:

-  Off
-  On

If DryPlus is turned on, the drying temperature is increased. This extends the drying time.



5.8 RinsePlus

Display on operating panel:  and 
Factory setting: 
Possible settings:

-  Off
-  On

If RinsePlus is turned on, the amount of water used with each programme is increased. This extends the programme time.



5.9 Hot water connection

Display on operating panel:  and **S**
Factory setting: 
Possible settings:



-  Off
-  On

If the appliance has a hot water connection, optimum use is made of the hot water.



5.10 Automatic standby

Display on operating panel:  and **S**
Factory setting: 
Possible settings:

-  Off
-  On

If the user setting is turned on, the information in the display is cleared at the end of the programme sequence. If set to «Off», the information is displayed until any button is pressed. ,  and  appear consecutively in the display at the end of the programme.

5.11 Factory setting

Display on operating panel:  and **S**
Factory setting: 
Possible settings:

-  No
-  Yes

With «Yes», the factory settings can be restored.

6 Care and maintenance

6.1 Cleaning the interior and exterior

Cleaning the interior

Using the correct dosage of detergent will automatically clean the interior of the appliance. The appliance should be additionally cleaned twice a year with dishwasher cleaner.

- ▶ Follow the instructions for the dishwasher cleaner.
- ▶ Select the  programme as dishwasher cleaners work more effectively at higher temperatures.

Cleaning the exterior

- ▶ Do not use abrasive or caustic cleaning agents.
- ▶ Do not use scouring pads, steel wool, etc. Otherwise the surface will be damaged.
- ▶ Remove any soiling or excess cleaning solution immediately. Only use washing-up liquid or glass cleaner.
- ▶ Clean the surfaces with a soft, damp cloth only – for metal surfaces rub in the direction of the polish lines.
- ▶ Clean the operating panel with a damp cloth and then wipe dry. Only use washing-up liquid or glass cleaner.
- ▶ Regularly clean the door seal and edges with a soft, damp cloth.

6.2 Cleaning the spray arms

Upper spray arm

- ▶ Remove the upper basket.
- ▶ Release bayonet fastener **1** in an anti-clockwise direction and remove.
- ▶ Remove the spray arm **2** from the shaft and rinse well under running water.
- ▶ Check the nozzles.

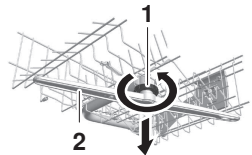

Lower spray arm

- ▶ Hold the spray arm **3** in the middle and pull hard upwards.
- ▶ Rinse the spray arm well under running water.
- ▶ Check the nozzles.
- ▶ Clean the filter system and the coarse filter at the same time.

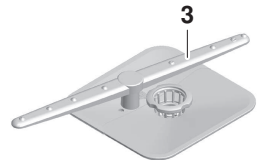

6.3 Cleaning the filter system



Only use soft materials for cleaning beneath the filter system. Never use metal objects.

An incorrectly assembled filter system can cause the appliance to malfunction.

- ▶ Open the appliance door and pull out the lower basket.
- ▶ Release the filter system in fine filter **1** in an anti-clockwise direction and remove.
- ▶ Open the coarse filter **2** by pressing on closing lug **3** and clean the filter system under running water using a brush.
- ▶ Remove any coarse debris.
- ▶ Replace the filter system and turn the fine filter **1** as far as it will go in a clockwise direction.

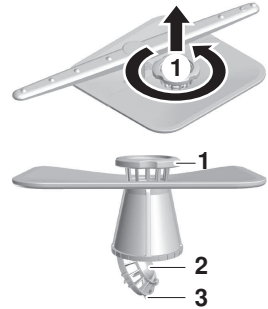

6.4 Refilling with regeneration salt



Never put detergent in the salt reservoir.

When the supply of regeneration salt is exhausted, the **S** refill indicator flashes.

- ▶ Open the appliance door and remove the lower basket.
- ▶ Open the cover on the salt reservoir by lifting up the grip.
- ▶ Fill with 1 kg standard regeneration salt. During the initial set-up, add an additional 1 l water.
- ▶ Wipe away any excess salt on the edge of the salt reservoir.
- ▶ Close the cover and engage the latch.
- ▶ Run the «Pre-rinsing» programme without dishes to protect the appliance from corrosion from any excess salt.



Approximate consumption of regeneration salt

A = Hardness of the water supply

B = Number of rinsing cycles per kg salt

A	°fH	0-5	6-10	11-15	16-20	21-25	26-30	31-40	41-50	51-70	71-120
	°dH	0-3	4-6	7-9	10-12	13-14	15-16	17-22	23-27	28-38	39-65
B		∞	680	360	250	150	125	90	60	40	20

6.5 Filling with rinse agent



Never put detergent in the rinse agent reservoir. Wipe off any spilt rinse agent. Foaming may occur. Follow the manufacturer's safety instructions and warnings.

Rinse agent prevents water spotting after final rinsing (rinsing with rinse agent).

When the supply of rinse agent is exhausted, the ✱ refill indicator flashes.

- ▶ Open the rinse agent reservoir by pushing the release catch in the direction of the arrow.
- ▶ Fill with rinse agent up to the «max» mark (1.3 dl = about 35 wash cycles).
- ▶ Close the cover.
- ▶ Wipe away any spilt rinse agent.

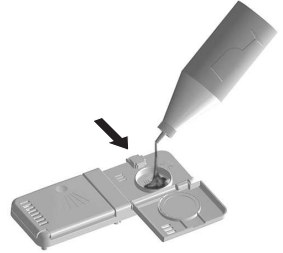













7 Trouble-shooting

You may be able to eliminate the following problems yourself. If not, write down the complete error message and the serial number (FN) on the identification plate of your appliance and call Customer Services.









7.1 Error messages

- In the event of a malfunction, an acoustic signal is emitted for 1 minute (depending on the model).

Display	Possible cause	Solution
 and  alternate.	<ul style="list-style-type: none"> ▪ High-foaming detergent was used. ▪ Spilt rinse agent. ▪ Washing-up liquid was used. 	<ul style="list-style-type: none"> ▶ Wipe away spilt rinse agent with a cloth. ▶ Get rid of the foam with approximately 1 dl vinegar. ▶ Cancel the error message by pressing the  button. ▶ Run the «Pre-rinsing» programme.
 and  alternate.	<ul style="list-style-type: none"> ▪ Filter system is clogged up. ▪ Drain hose is bent or kinked. ▪ Drain pump or siphon is blocked. ▪ Excessive foaming due to rinse agent spillage. 	<ul style="list-style-type: none"> ▶ Clean the filter system. ▶ Fix the problem. ▶ Cancel the error message by pressing the  button. ▶ Restart the programme.
 and  alternate.	<ul style="list-style-type: none"> ▪ Water tap is turned off. ▪ Water inlet filter is blocked. ▪ Interruption in the water supply. ▪ Water pressure is too low. 	<ul style="list-style-type: none"> ▶ Fix problem or wait until water supply is restored. ▶ Cancel the error message by pressing the  button. ▶ Restart the programme.
 ,  and  alternate.	<ul style="list-style-type: none"> ▪ Water intake is hotter than 79 °C (hot water connection). 	<ul style="list-style-type: none"> ▶ Have a plumber reduce the temperature of the water intake.









Display	Possible cause	Solution
E and I alternate.	<ul style="list-style-type: none"> ▪ Various situations can lead to an «E» message. 	<ul style="list-style-type: none"> ▶ Cancel the error message by pressing the DI button. <p>If the error message persists:</p> <ul style="list-style-type: none"> ▶ Switch the power supply off for about 1 minute. ▶ Switch the power supply back on again. ▶ Cancel the error message by pressing the DI button. ▶ Restart the programme. ▶ If the error appears again, note down the error message and FN. ▶ Turn off the water tap and the power supply. ▶ Call Customer Services.
E and I alternate.	<ul style="list-style-type: none"> ▪ Faulty electrical connection. ▪ Overvoltage. 	<ul style="list-style-type: none"> ▶ Cancel the error message by pressing the DI button. <p>If the error message persists:</p> <ul style="list-style-type: none"> ▶ Switch the power supply off for about 1 minute. ▶ Switch the power supply back on again. ▶ Cancel the error message by pressing the DI button. ▶ Restart the programme. ▶ If the error appears again, note down the error message and FN. ▶ Switch the power supply off. ▶ Have the electrical installation checked by an expert.

7.2 Other possible problems

Problem	Possible cause	Solution
The appliance will not start.	<ul style="list-style-type: none"> ▪ There could be several reasons for this. 	<ul style="list-style-type: none"> ▶ Close the appliance door. ▶ Insert plug into mains socket. ▶ Check the fuse or circuit breaker. ▶ See the «Operation with the childproof lock activated» section.
	<ul style="list-style-type: none"> ▪ «Demo mode» is turned on. 	<ul style="list-style-type: none"> ▶ Hold the  and  buttons depressed and at the same time press the  button. <p> appears in the display.</p> <ul style="list-style-type: none"> ▶ Press the  button. <p>In the display appears: </p> <ul style="list-style-type: none"> ▶ Cancel the display by pressing the  button.
An unpleasant smell tends to come from the appliance.	<ul style="list-style-type: none"> ▪ There could be several reasons for this. 	<ul style="list-style-type: none"> ▶ Clean the filter system. ▶ Add detergent and run the  programme. ▶ Select a more powerful programme. ▶ Refill the salt reservoir with enough regeneration salt.

7.3 Unsatisfactory washing results

Problem	Solution
The dishes are not clean.	<ul style="list-style-type: none"> ▶ Select a more powerful programme. ▶ Load the baskets differently, avoiding blind spots. ▶ Clean the filter system and re-insert correctly. ▶ Check to see whether the spray arms are clogged or dirty. ▶ Use the correct amount of detergent or use a different kind of detergent. ▶ Check the water hardness setting. ▶ Refill the salt reservoir with regeneration salt.

Problem	Solution
There is a white film on the dishes.	<ul style="list-style-type: none"> ▶ Clean the appliance with dishwasher cleaner. ▶ Refill the salt reservoir with regeneration salt and run the  programme without any dishes. ▶ Use the correct amount of detergent or use a different kind of detergent. ▶ Refill the rinse agent. ▶ Increase the rinse agent dosage setting. ▶ Check the water hardness setting. ▶ If not using  detergent, set  to  in the user settings.
There are streaks or milky spots on the dishes.	<ul style="list-style-type: none"> ▶ Reduce the rinse agent dosage setting. ▶ If not using  detergent, set to  in the user settings.
The dishes are wet and dull or have water marks on them.	<ul style="list-style-type: none"> ▶ Refill the rinse agent. ▶ Increase the rinse agent dosage setting. ▶ Use a different rinse agent. ▶ Do not open the appliance door until the end of the programme when a triple acoustic signal is emitted and the display or function light goes out (depending on model). ▶ If not using  detergent, set  to  in the user settings.
There are rust spots on the items being washed.	<p>The rust stems from another source e.g. the cutlery, pans, water pipe. The appliance is made of rust-free steel.</p> <ul style="list-style-type: none"> ▶ Refill the salt reservoir with regeneration salt and run the «Pre-rinsing» programme without dishes.
The detergent is not fully dissolved.	<ul style="list-style-type: none"> ▶ Check to see whether the spray arms are clogged or dirty. ▶ Use a different kind of detergent. ▶ Check the detergent dispenser cover. ▶ Check whether the filter system is clogged.
There is discolouring of the baskets and plastic parts inside the appliance.	<p>Dishes were washed that still had discolouring food leftovers on them (e.g. tomato or curry sauce). The discolouration may fade after a few wash cycles.</p>

7.4 In the event of a power failure

- Any programme that is running will be interrupted. After the cause of the power supply failure has been resolved, the programme is resumed.
- The fault indication system is interrupted.

8 Accessories and spare parts

Please give product family of the appliance and exact designation of the accessory or spare part when ordering parts.

Accessories

«Small» cutlery basket

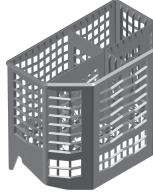

«Large» cutlery basket



Cup support

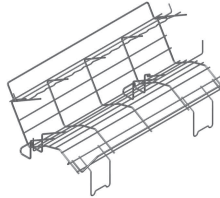

Vario cutlery basket insert

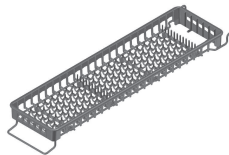

Lower basket for glasses

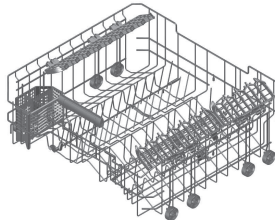

Racks



Set of 4 easy prongs



Spare parts

Filter system



9 Technical data

Dimensions	SMS 55	SMS 55 Extra height	EURO 60	EURO 60 Extra height
Appliance height (incl. slide plate 3 mm)	762 mm	827 mm	762 mm	827 mm
Appliance height (incl. adjustable plinth)	–	848–893 mm	783–828 mm	848–893 mm
Appliance width	546 mm	546 mm	596 mm	596 mm
Appliance depth	572 mm	572 mm	572 mm	572 mm
Appliance weight	42–48 kg			

Plumbing in

Cold or hot water up to 60 °C:	G $\frac{3}{4}$ "
Permitted pressure of water supply:	0.1–1.0 MPa (1–10 bar)
Max. pumping height:	1.2 m

Electrical connection

See identification plate:

- ▶ Open the appliance door.
 - Identification plate is located on left-hand side on edge of tub.

Ambient conditions

Minimum ambient temperature: +10 °C

Safety concept

Provided power is going to the appliance, the electronic control unit monitors the appliance. Any malfunctions are indicated by error messages.

Overflow protection



The overflow protection system does not work in the event of a power failure. Turn off the water tap during longer periods without operation.

The electronic control unit monitors the water level in the appliance. In the event of a malfunction, the drain pump turns on, stopping the supply of water to the appliance.

9.1 Consumption data

V	=	Pre-rinsing	T	=	Drying
R	=	Cleaning	D	=	Duration
Z	=	Intermediate rinsing	W	=	Water
G	=	Rinsing with rinse agent	E	=	Energy

The stated programme times and consumption values serve as a guide. The values can also vary according to the selection of additional functions, the load, the degree of soiling of the load, the type and amount of cleaner, the water inlet temperature, the electrical connection and specific programme sequences (e.g. regeneration).

Programme	V [°C]	R [°C]	Z	G [°C]	T	D*	W [l]	E [kWh]
Automatic	If required (cold)	50 – 60	If required	55	Yes	1h05 – 2h00	5 – 18	0.8 – 1.4
Quick wash / Glass care	No	45	Yes	60	Yes	0h39	11	0.8
Intensive	If required (35)	65	Yes	70	Yes	1h50	18 – 23	1.4 – 1.65
Pre-rinsing	Cold	No	No	No	No	0h07	4	0.05
Eco pro- gramme	Yes	50	No	40	Yes	2h15	11	0.6

* Duration without final drying time.

9.2 Note for testing institutes

The note for testing institutes can be obtained from the internet:
www.vzug.com/testinstitute.

9.3 Noise measurement

See the 'Note for testing institutes' section.

10 Disposal

10.1 Packaging



Never allow children to play with packaging material due to the danger of injury or suffocation. Store the packaging material in a safe location or dispose of it in an environmentally-friendly way.

10.2 Safety

Render the appliance unusable to prevent accidents caused by improper use (e.g. through children playing):

- ▶ Disconnect the appliance from the mains. With a fixed appliance, this is to be carried out by a qualified electrician. Then cut the mains cable off flush with the appliance.
- ▶ Remove or disable the lock on the appliance door.

10.3 Disposal



-  The «crossed out wheeled bin» symbol requires the separate collection of waste electrical and electronic equipment (WEEE). Such equipment can contain hazardous, environmentally harmful materials.
- These appliances are to be handed over to a designated collection point for the recycling of electrical and electronic equipment and must not be disposed of with unsorted household waste. And in this way, you will be helping to protect resources and the environment.
- For more information, please contact the local authorities.

11 Notes

Quick start guide

Please first read the safety precautions in the operating instructions!

- ▶ Open the appliance door.
- ▶ Load the dishes.
- ▶ Add the detergent.
- ▶ Select the programme.
- ▶ Select any additional function(s) required.
- ▶ Close the appliance door. The programme starts immediately, or after 15 seconds (depending on model).
- ▶ When a 3× acoustic signal is emitted or the display goes out (depending on model), open the appliance door and unload the dishes.

Services & support

Register your appliance today online via our website at www.vzug.com and benefit from the best possible support in the event of a malfunction – including during the manufacturer's 2-year warranty period. You will require the serial number (FN) and appliance designation to register your appliance. You will find them on the identification plate of your appliance.

You can make your own note of the FN and appliance designation or note them on the service sticker which comes with the appliance:

FN: _____

Appliance: _____

Your repair order

You can find the telephone number of the nearest V-ZUG service centre to you under www.vzug.com →Service →Service hotline.

General queries, accessories and service agreement

V-ZUG will be happy to help you with any general administrative or technical queries, to accept your orders for accessories and spare parts and to inform you about our progressive service agreements.

