

Combi Steam Cooker

Combi-Steam XSL

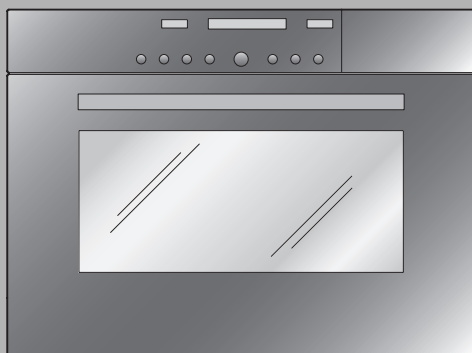

Operating instructions

Thank you for choosing to buy one of our products. Your appliance is made to high standards and is easy to use. Nevertheless, please take the time to read these operating instructions in order to familiarize yourself with the appliance and get the best use out of it.

Please follow the safety precautions.

Modifications

Text, diagrams and data correspond to the technical standard of the appliance at the time these operating instructions went to press. The right to make technical modifications for the purpose of the further development of the appliance is reserved.

Symbols used



Denotes important safety precautions. Failure to observe said precautions can result in injury or damage to the appliance or fittings!

- ▶ Indicates step-by-step instructions.
- Describes how the appliance reacts to the steps taken.
- Indicates a list.



Denotes useful tips for the user.

Validity

The model number corresponds to the first three digits on the identification plate. These operating instructions apply to the model:

Type	Model no.	Size system
CST-XSLZ/60	864	60-450

Contents

1	Safety precautions	6
1.1	Before using for the first time	6
1.2	Correct use	7
1.3	Children in the home	8
1.4	Note on use	8
2	Appliance description	11
2.1	Construction	11
2.2	Operating and display elements	12
2.3	Cooking space	13
2.4	Accessories	14
3	Operating the appliance	19
3.1	Using for the first time	21
3.2	Example	21
3.3	Filling the water tank	22
3.4	Selecting the operating mode	23
3.5	Changing the operating mode	23
3.6	Selecting the cooking space temperature	24
3.7	Checking/Changing the cooking space temperature	24
3.8	Switching off	25
3.9	Emptying the water tank	25
4	User settings	26
4.1	Language	28
4.2	Childproof lock	28
4.3	Time display	29
4.4	Acoustic signal	29
4.5	Illumination	29
4.6	Water hardness	30
4.7	Temperature unit	30
4.8	Contrast	30
4.9	Time format	30
4.10	Flap control	31
4.11	Factory settings	31

5	Time functions	32
5.1	Setting/Changing the time	32
5.2	Timer	33
5.3	Operating time	35
5.4	Delayed start	37
6	Operating modes	40
7	Food probe	44
7.1	Positioning the food probe	44
7.2	Food probe temperature	45
8	Soft roasting	47
9	BakeOmatic	50
9.1	Degree of browning	50
9.2	Cooking/Baking times	50
9.3	Selecting and starting BakeOmatic	52
10	GourmetSteam	54
10.1	Selecting and starting GourmetSteam	55
11	Recipes	57
11.1	Selecting and starting a recipe	58
12	Own recipes	60
12.1	Creating own recipes	60
13	Keeping cooked food warm	63
14	Tips and tricks	64
14.1	Hygiene	68
14.2	Saving energy	68
15	Descaling	69
15.1	Operating time remaining to descaling	69
16	Care and maintenance	73
16.1	Cleaning the exterior	73
16.2	Cleaning the appliance door	74
16.3	Removing the shelf guides	75
16.4	Replacing the door seal	75
16.5	Cleaning the accessories	75
16.6	Cleaning the cooking space	76
16.7	Replacing a defective light bulb	76

17 Trouble-shooting	77
17.1 What to do if ...	77
17.2 After a power failure	80
18 Accessories and spare parts	81
19 Technical data	84
20 Disposal	86
21 Notes	87
22 Index	88
23 Repair service	91

1 Safety precautions



The appliance corresponds to recognised technology standards and the relevant safety regulations. Proper use of the appliance is however essential to avoid damage and accidents. Please therefore follow the precautions given in these operating instructions.

In accordance with the requirements of IEC 60335-1:

- This appliance is not intended for use by persons (including children) with reduced physical, sensory or mental capabilities, or lack of experience and knowledge, unless supervised or unless they have been given instruction concerning the use of the appliance by a person responsible for their safety.

1.1 Before using for the first time

- The appliance must be installed and connected up to the power supply in accordance with the separate installation instructions. The necessary work should be done by a qualified fitter or electrician.
- Dispose of the packaging material in accordance with local regulations.
- Before using the newly installed appliance for the first time, please follow the advice in the USING FOR THE FIRST TIME section.
- Make the desired user settings.

1.2 Correct use

- The appliance is designed for use in the home for preparing food. Under no circumstances flambé or cook food using a lot of fat in the cooking space! No liability is assumed for any damage caused by improper or incorrect use.
- Never use the appliance to dry animals, textiles or paper!
- Not to be used as a room heater or humidifier.
- The appliance should only be installed and operated in a room with an ambient temperature of between 5 °C and 35 °C. In the event of frost, there is a danger that residual water left in the pumps can freeze, causing damage.
- Only use the food probe supplied with this appliance.
- Any repairs, modifications or manipulations to the appliance, especially any electrically live parts, should only be carried out by the manufacturer, its Customer Services or similarly qualified persons. Repairs if carried out incorrectly may cause serious injury, damage to the appliance and fittings, as well as affect the functioning of the appliance. If the appliance is not working properly or in case of a repair order, follow the instructions given in the REPAIR SERVICE section. Please contact Customer Services if necessary.
- Only original spare parts may be used.
- Retain these operating instructions for future reference. If you sell the appliance or pass it on to a third party, please ensure these operating instructions accompany the appliance, together with the instructions on installation. In this way, the new owner can inform themselves about how to use the appliance correctly and read the pertinent safety precautions.

1.3 Children in the home

- Packaging material, e.g. plastic and polystyrene, can be dangerous for children. Danger of suffocation! Please keep packaging material away from children.
- The appliance is designed for use by adults who are familiar with these operating instructions. Children are often unable to recognise the danger of electrical appliances. Ensure proper supervision and do not allow children to play with the appliance – there is a danger that children can hurt themselves.
- Use the childproof locking facility.

1.4 Note on use

- If the appliance is visibly damaged, do not use it. Contact our Customer Services.
- If the appliance is not operating properly, disconnect it from the power supply immediately.
- Ensure the mains cables of other electrical appliances do not get caught in the door of the appliance, as the electrical cable insulation could get damaged.
- If the mains cable of the appliance is damaged, it must be replaced by Customer Services in order to avoid hazard.
- Ensure there are no foreign bodies or pets in the cooking space before closing the appliance door.
- Objects that could pose a danger if the appliance were accidentally switched on should not be stored in the cooking space. Do not store food nor any temperature-sensitive or inflammable materials, e.g. cleaning agents, oven sprays, etc., in the cooking space.

Caution: Burns hazard!

- The appliance gets very hot when in use.
- Heat is produced during cooking and baking. The appliance door, especially the glass, can get hot. Burns hazard – do not touch. Keep children away!
- The appliance will remain hot for some time after it is switched off and will cool down only slowly to room temperature. Please allow sufficient time for the appliance to cool down before, for instance, cleaning it.
- Steam may escape from the cooking space when the appliance door is opened. Do not put your hands into the cooking space if there is steam in it!
- Hot steam may escape from the steam vent during operation.
- Overheated fat and oil can easily catch fire. Heating oil in the cooking space to sear meat is dangerous and should not be done. Never try to extinguish burning oil or fat with water – danger of explosion! Smother the flames with a fire blanket and keep all doors and windows closed.
- Do not pour spirits (e.g. brandy, whisky, schnapps, etc.) over hot food – danger of explosion!
- Do not leave the appliance unsupervised when drying herbs, bread, mushrooms, etc. If the foodstuff dries out too much, this can pose a fire hazard.
- If you notice smoke possibly coming from the appliance itself or from inside the cooking space, keep the appliance door closed. Disconnect the appliance from the power supply.
- Accessories get hot in the cooking space. Always wear protective gloves or use oven cloths.

Caution: Danger of injury!

- Be careful not to put fingers in the door hinges, there is otherwise a risk of injury if the appliance door is moved. Particular care should be taken when children are around.
- Only leave the appliance door open in the at-rest position. An open appliance door poses a danger of tripping or injury! Do not sit or rest on the appliance door or use it as a storage surface.

How to avoid damaging the appliance

- Close the appliance door carefully.
- Do not place any protective insert or aluminium foil on the bottom of the cooking space as this can result in an optical change in the cooking space floor.
- Do not place things on the panel flap in front of the water tank.
- Do not use knives or cutting wheels on the stainless steel tray, enamelled baking trays, in cooking utensils and on the steam insert. This will visibly damage them.
- Do not use objects that can rust in the cooking space.
- Do not use silver cutlery in the cooking space.
- To prevent corrosion, allow the cooking space to dry and leave the appliance door open in the at-rest position until the cooking space has cooled down.
- When cleaning the appliance make sure no water gets inside the appliance. Use a moderately damp cloth. Do not spray the inside or outside of the appliance with water. Do not use a steam cleaner. If water gets inside the appliance, it can cause damage.

2 Appliance description

2.1 Construction

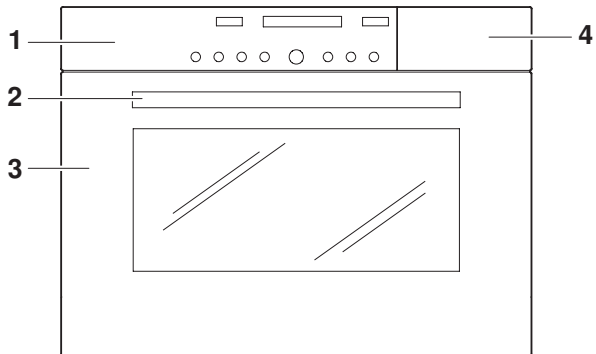





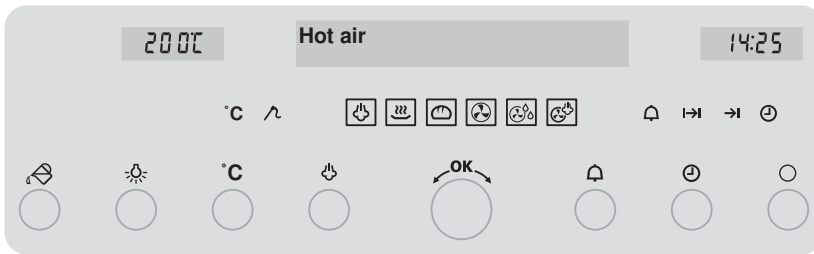



- 1 Operating and display elements
- 2 Door handle
- 3 Appliance door
- 4 Panel flap in front of water tank



2.2 Operating and display elements









Button

	Flap opener		Adjusting knob
	Illumination		Timer
	Cooking space/ food probe temperature		Time, operating time, switch-off time
	Operating mode		Off

Displays

	Temperature		Plain text display
	Time, operating time, switch-off time, timer		

Symbols

	Cooking space temperature		Operating time
	Food probe temperature		Switch-off time
	Timer		Time

 Operating modes

2.3 Cooking space



Do not place any protective insert or aluminium foil on the bottom of the cooking space.

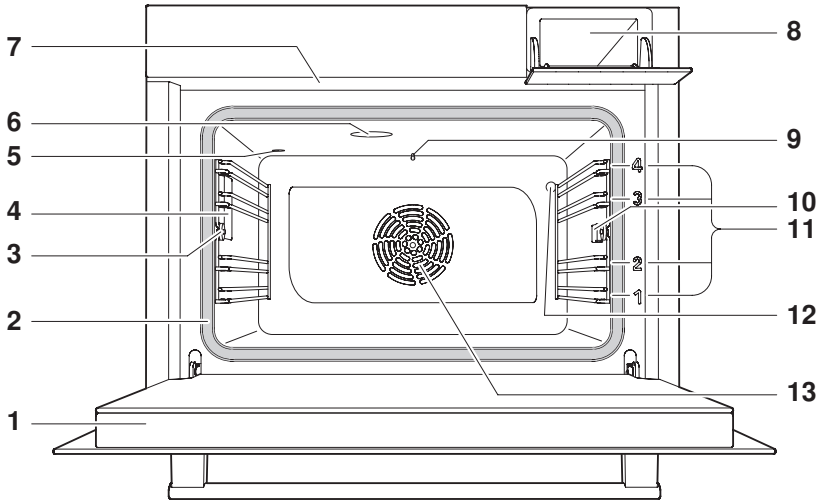

- | | |
|------------------------------------|---|
| 1 Appliance door | 8 Water tank compartment |
| 2 Door seal | 9 Cooking space temperature sensor |
| 3 Knurled nut | 10 Socket for food probe |
| 4 Illumination | 11 Levels |
| 5 Climate sensor | 12 Steam inlet |
| 6 Cooking space ventilation | 13 Hot air fan |
| 7 Ventilation outlet | |

2.4 Accessories







Do not use knives or cutting wheels on the stainless steel tray, enamelled baking trays, in cooking utensils and on the steam insert. This causes visible damage.

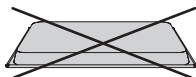

1



Original baking tray with TopClean

- Serves as a baking tin for flans and biscuits.
- If not fully covered by the baking, the shape of the original baking tray can become distorted during baking. This is normal. As it cools down, the original baking tray will go back to its original form.
- ▶ Always push the «sloped» side **1** of the original baking tray right to the back of the cooking space.
- Not suitable for use with the , ,  and  operating modes.
- ▶ The original baking tray is to be used the normal way round – not upside down.

Stainless steel tray

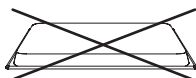
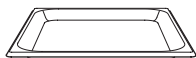

- Serves as a baking tin for aperitif nibbles and bread.
- Use together with the wire shelf or perforated cooking tray as a drip tray.
- If not fully covered by the baking, the shape of the stainless steel tray can become distorted during baking. This is normal. As it cools down, the stainless steel tray will go back to its original form.
- ▶ The stainless steel tray is to be used the normal way round – not upside down.

Wire shelf



- For standing roasting and baking tins on.
- For standing meat, frozen pizza, etc. on.
- Serves as a cooling rack.

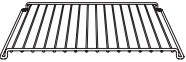

For preparing frozen bread rolls and quiche.

- Cover the wire shelf with baking paper or use a round baking tray.

Perforated cooking tray

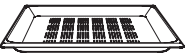

- For cooking fresh or frozen vegetables, meat and fish.
 - For standing ramekins, preserving jars, etc. on.
 - For extracting juice from berries, fruit, etc.
- For steaming, place the stainless steel tray underneath the perforated cooking tray to catch any food spills or condensate



Food probe with straight handle

The food probe is suitable for measuring the core temperature of food between the range of 30 °C to 99 °C.

- As soon as the set food probe temperature is reached, the appliance switches off automatically. A guide to appropriate food probe temperatures can be found in TIPS ON SETTINGS.
- The food probe can also be simply used to measure the core temperature. In this case, the operating mode must be switched off manually.
- The food probe can be used with all operating modes.

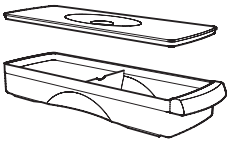

Water tank with lid





- Only fill with fresh, cold drinking water.
- Do not use demineralised (filtered) or distilled water.

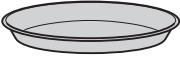

The following accessories are not included in the scope of delivery.



Round TopClean baking tray

- Baking tin for flans and quiches.
- Not suitable for use with the , ,  and  operating modes.

Available in 3 different sizes.

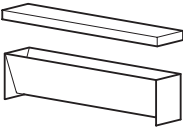

Terrine mould with lid

- For preparing vegetable, fish and meat terrines.
- For preparing ice cream, parfait and other sweets.

Available in 2 different designs.



Porcelain dish

- For preparing various dishes such as lasagne, potato gratin, etc.
- For steaming and keeping food warm.

Available in 3 different sizes.

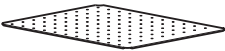

Stainless steel steam insert

- For the steaming of vegetables, potatoes, etc. in combination with a porcelain dish.

Available in 3 different sizes.

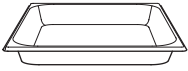

Unperforated cooking tray

- For cooking meat, fish, sauerkraut, rice, millet, cereal products, soaked pulses, chickpeas, etc.
- Available in different sizes and depths.

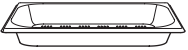

Perforated cooking tray

- For cooking fresh or frozen vegetables, meat and fish.
- Available in different sizes and depths.

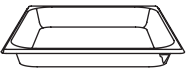

Unperforated cooking tray with lip

- For extracting juice from berries, fruit, etc.
- Serves as a drip tray for collecting condensate from food.

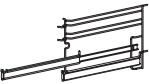



Roller runner

- For safely pulling out one or more baking trays/wire shelves in order, for instance, to baste a joint of meat or to take out a baking tin.

3 Operating the appliance





Using the buttons

The operating mode, the cooking space temperature, the food probe temperature, the operating time, the switch-off time and various other functions can be selected by pressing the appropriate button once or more.

- The symbol for the function selected illuminates or flashes.
- A recommendation flashes in the corresponding digital display.
- Turn the  adjusting knob to change the setting.
- Press the  adjusting knob to confirm the setting or it will be automatically accepted after 10 seconds.
- Other settings or changes can be made at any time.
- Press the  button to switch off the appliance.



Using the plain text display

When the appliance is switched off, the  adjusting knob is used to display text, to view the different selection options and to confirm.

- Press the  adjusting knob to activate the plain text display.
- Turn the  adjusting knob to view the selection options.
- Press the  adjusting knob again to confirm the selection.
- Press the  button to turn off the plain text display.

3 Operating the appliance



To return to the previous operating level, select «back» and press the  adjusting knob. The  symbol indicates additional information.

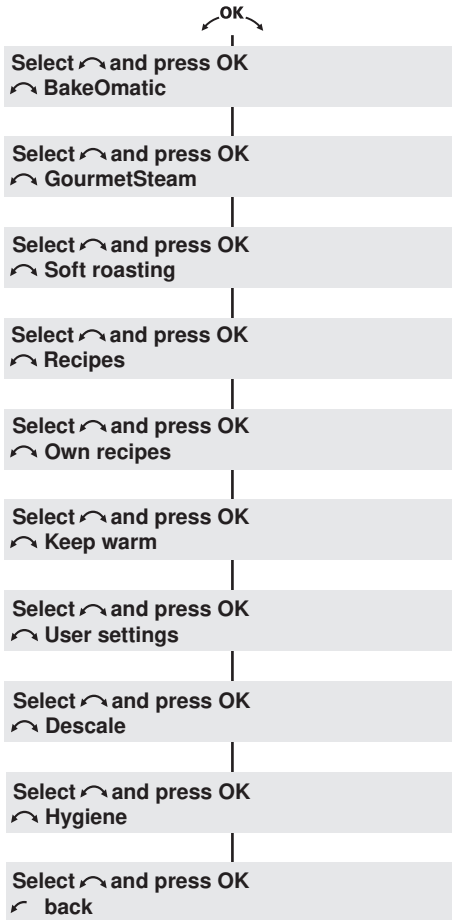



3.1 Using for the first time

Before using the newly installed appliance for the first time the following measures should be taken:

- Remove all packaging and transport materials from the cooking space.
- When **12:00** flashes in the right digital display, turn the  adjusting knob to set the time.



Press the  adjusting knob to switch between hours and minutes. Turn it to set the hours and the minutes.

Press the  adjusting knob to confirm the setting.







- Clean the cooking space and the accessories.
- If necessary, adjust the water hardness in the user settings.
- Heat the empty cooking space (i.e. without the wire shelves, baking trays, etc.) using the  operating mode for about 30 minutes at 210 °C.

3.2 Example



Burns hazard from heat produced during cooking and baking! Use protective gloves or oven cloths. Keep children away.

The symbols are explained in TIPS ON SETTINGS. The tables in TIPS ON SETTINGS give:

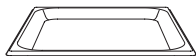
			°C		 Mins.		
Bread	A11		200-210	no	40-50	2	

- Put the stainless steel tray into the cold cooking space at level 2.
- Next steps are described on the following sides.









If selecting a  «BakeOmatic» programme, operate the appliance as described in the **BAKEOMATIC** section.

3.3 Filling the water tank



Only fill the water tank with fresh, cold drinking water. Do not use demineralised (filtered) or distilled water.

Do not place things on the panel flap in front of the water tank when open.

- ▶ Press the  button.
 - The panel flap in front of the water tank opens.
- ▶ Fill the water tank with fresh, cold water drinking water and close the lid.
- ▶ Push the water tank into the special compartment.
- ▶ Close the panel flap manually.
- For the , ,  and  operating modes as well as «BakeOmatic», «GourmetSteam» «Recipes» and «Own recipes», the filled water tank must be in position in the water tank compartment.
- For the  and  operating modes as well as «Soft roasting», the water tank can stay in the water tank compartment without it affecting the end cooking result.

Refilling the water tank

The contents of the water tank normally suffice for one cooking session.

If, however, the water tank needs to be refilled:

- ▶ Press the  button.
 - The panel flap in front of the water tank opens.









With the «Automatically with messages» setting, the panel flap in front of the water tank opens automatically.

The panel flap in front of the water tank can be opened at any time by pressing the  button.

- ▶ Do not fill the water tank with more than 0.5 l water to ensure that it does not overflow when the water is pumped back.

3.4 Selecting the operating mode



- Select the  operating mode.
 - «Professional baking» « level 2 or 1+3» appears in the plain text display.
 - The recommended temperature flashes in the left digital display.
 - The  and °C symbols flash.
- Press the  adjusting knob to confirm.
 - «Professional baking» « Steam phase» and then «Professional baking» « Hot air phase» appears in the plain text display.





The recommended temperature corresponds to the temperature of the hot air phase. The temperature of the steam phase is predetermined.

3.5 Changing the operating mode



The operating mode selected cannot be changed during operation.

- Press the  button.
 - The operating mode selected is ended.
- Press the  button to select a new operating mode.

3.6 Selecting the cooking space temperature

- ▶ Press the °C button.
- ▶ Turn the  adjusting knob to set the desired cooking space temperature.
- ▶ Press the  adjusting knob to confirm.
 - «Professional baking» «Steam phase» appear in the plain text display.



For the  /  and  operating modes, a single acoustic signal is emitted when the set cooking space temperature is reached.

3.7 Checking/Changing the cooking space temperature

- ▶ Press the °C button.
 - «Cooking space temperature» appears in the plain text display.
 - The set cooking space temperature flashes in the left digital display.
 - The °C symbol flashes.

The cooking space temperature can be changed by turning the  adjusting knob.

Removing the cooked food from the cooking space





Hot steam or hot air may escape from the cooking space when the appliance door is opened. Burns hazard!

The accessories will be hot. Burns hazard! Use protective gloves or oven cloths.

- ▶ Take the bread loaf out of the cooking space when ready.
- ▶ Place it on the wire shelf and allow to cool down.

3.8 Switching off

- ▶ Press the  button.
 - The  and  symbols go out.
 - For all operating modes that use steam, steam can be released at the end of the cooking process.
 - The steam is gradually released from the cooking space – this take around 1 minute – so that there is no sudden rush of steam when the appliance door is opened.
 - The cooling fan can continue to run.
 - «Residual heat» appears in the plain text display.



When the symbols are no longer illuminated and the plain text display is dark the appliance is off.

- ▶ Any condensate or food in the cooking space – after each cooking session with steam – must be dried completely or removed.
- ▶ To prevent corrosion, leave the appliance door open in the at-rest position until the cooking space has cooled down.

3.9 Emptying the water tank



The water in the water tank can be hot. Scalding hazard!

When the appliance is switched off, the residual water is pumped back into the water tank.

- « Water is being pumped off» appears in the plain text display.
- ▶ When the water has been pumped back, remove, empty and then dry the water tank.









If « Do not remove water tank» is displayed in the plain text display, then the temperature of the residual water is still over 80 °C. For safety reasons, the residual water is not pumped back until its temperature drops below the 80 °C mark.

Any operating mode can be started again at any time.

4 User settings

You can adjust the settings.

- ▶ Press the  adjusting knob to activate the plain text display.
 - «Select  and press OK» «BakeOmatic» appears in the plain text display.
- ▶ Turn the  adjusting knob until «User settings» appears.
- ▶ Press the  adjusting knob to confirm.
 - «User settings» «Language» appears in the plain text display.
- ▶ Turn the  adjusting knob to display the available options.
- ▶ Select setting and press the  adjusting knob to confirm.
- ▶ Press the  button to exit.



The settings are retained in the event of a power failure.

Possible settings

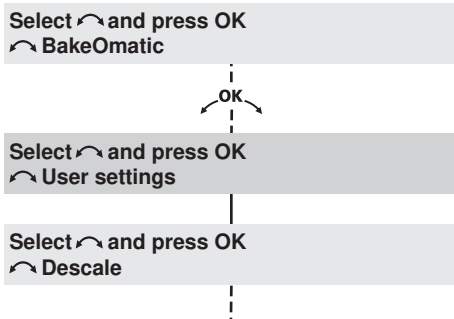

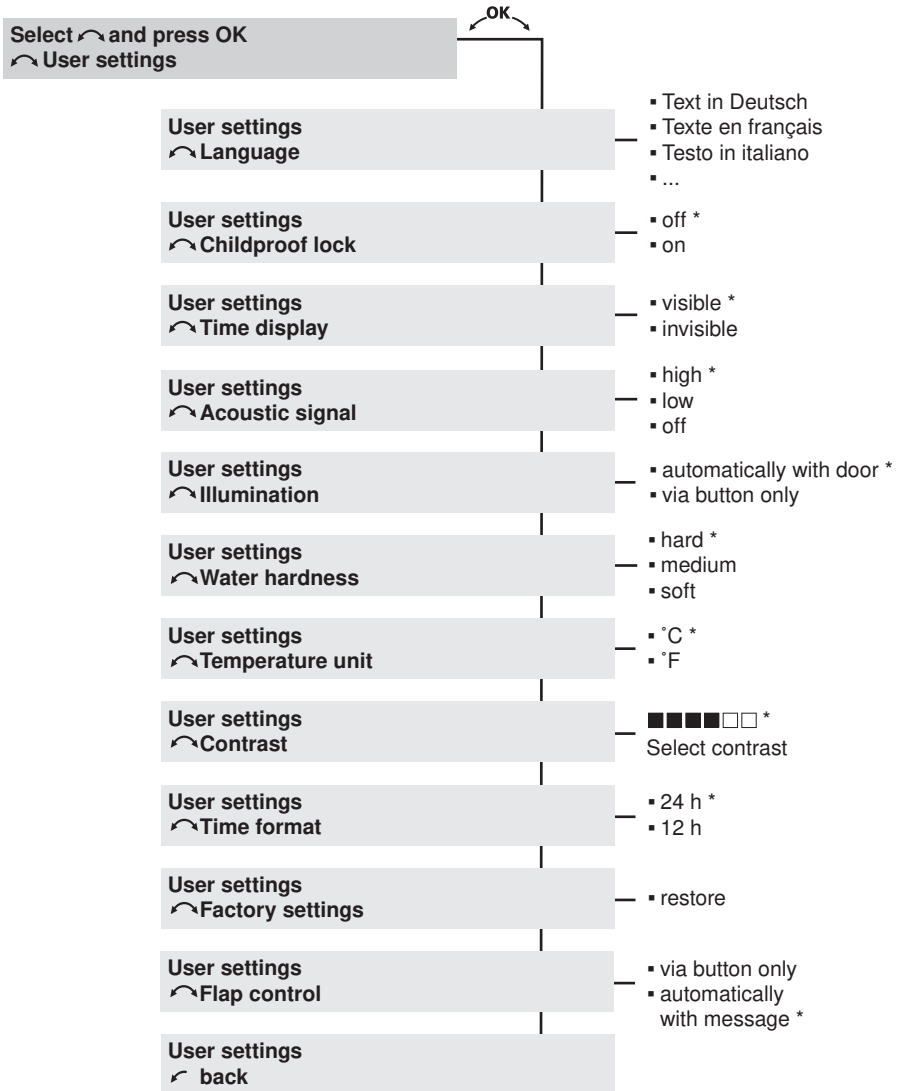





* Factory setting



4.1 Language

Different languages are available for selection. The language in the plain text display can be changed.

- ▶ Press the  button and the  adjusting knob simultaneously for 10 seconds.
 - «Language» appears in the plain text display.
- ▶ Turn the  adjusting knob until the desired language appears.
- ▶ Press the  adjusting knob to confirm.





4.2 Childproof lock

The childproof lock to prevent the appliance being inadvertently switched on.



If the ,  or  buttons are pressed when the childproof lock is activated:

- A double acoustic signal is emitted.
- «Childproof lock» appears in the plain text display.
- Nothing happens when either button is pressed.

Operating the appliance when the childproof lock is activated

- ▶ Hold the  button depressed and press the ,  or  buttons.
 - The childproof lock is overridden. The appliance can be operated as normal.
 - The childproof lock is automatically reactivated 10 minutes after the appliance has been switched off.



The  /  and  buttons can be used irrespective of whether the childproof lock is activated or not.

4.3 Time display

If «invisible» is selected, the time display is not illuminated when the appliance is off, minimizing power consumption. When the appliance is on, the time is displayed.



To reduce power consumption to an absolute minimum, select «Time display» «invisible» in the user settings. Despite automatic energy-saving stand-by, all safety functions are active. All displays go out when the cooking process has been completed.

4.4 Acoustic signal

The acoustic signal can be set at one of two levels of loudness or can be switched off.

• High	Maximum loudness
• Low	Reduced loudness
• Off	Acoustic signal is switched off





Even if the acoustic signal setting is set to «off», an acoustic signal is emitted in the event of a malfunction.

4.5 Illumination

With the «automatically with door» setting, the illumination automatically comes on when the appliance door is opened and goes off again when it is closed.



Press the  button to switch the illumination on or off at any time. If the illumination is not switched off by pressing the  button, it will go off automatically 30 minutes after use.

4.6 Water hardness

The appliance features a system that automatically indicates when it is time to descale. The system can be optimised for households with soft water (also through using a water softening appliance) and medium water hardness by changing the user settings to the relevant range of water hardness.

There are three settings for water hardness:

Type	Water hardness [°fH]	Water hardness [°dH]	Water hardness [°eH]
• Hard	36 to 50	21 to 28	26 to 35
• Medium	16 to 35	9 to 20	12 to 25
• Soft	1 to 15	1 to 8	1 to 11

4.7 Temperature unit

For temperature unit, select between «°C» and «°F».

• °C	Degrees Celsius
• °F	Degrees Fahrenheit

4.8 Contrast

With this function, the readability of the display can be adjusted based on how the appliance is installed.

4.9 Time format

Select the «24 h» setting to activate the European time format and the «12 h» setting for the US time format (a.m./p.m.).

4.10 Flap control

If the water tank is empty during operation with steam, the panel flap in front of the water tank opens automatically with the setting «automatically with messages».



With the setting «flap control» you can select between manual or automatic flap opening.

The panel flap in front of the water tank can be opened at any time by pressing the  button.

4.11 Factory settings

If one or more user settings have been changed, these can be reset to the factory settings.

5 Time functions

The following time functions are available:

- Time
- Timer – the timer can be used at any time and independently of all other functions
- Operating time – time-controlled switch-off of the appliance
- Delayed start – time-controlled switch-on and switch-off of the appliance.











When the appliance is switched off, the display is dimmed between 24:00 and 6:00.

If the «12 h» time format has been selected, the display is not dimmed.

5.1 Setting/Changing the time



The time cannot be changed if the appliance is in operation or if a delayed start has been set.





- ▶ Press the  button.
 - «Time: set hours» « Minutes: press OK» appears in the plain text display.
 - The hour flashes in the right digital display.
 - The  symbol flashes.
- ▶ Turn the  adjusting knob to set the hour.
- ▶ Press the  button or the  adjusting knob.
 - «Time: set minutes» « Confirm: press OK» appears in the plain text display.
 - The minutes flash in the right digital display.
 - The  symbol flashes.
- ▶ Turn the  adjusting knob to set the minutes.

Press the  adjusting knob to confirm the setting.



5.2 Timer

The timer functions like an egg timer. It can be used at any time and independently of all other functions.

Setting

- ▶ Press the  button.
 - «Timer: set hrs./mins.» appears in the plain text display.
 -  flashes in the right digital display.
 - The  symbol flashes.
- ▶ Turn the  adjusting knob to set the timer duration.



The timer can be set for:

- up to 10 minutes in 10-second intervals, e.g.  = 9 minutes and 50 seconds.
- over 10 minutes in 1-minute intervals, e.g.  = 1 hour and 12 minutes.

The maximum timer duration that can be set is 9 hours and 59 minutes.



Press the  button 1× to reset the timer duration to .



- ▶ Press the  adjusting knob to start the timer.
 - «Timer» appears in the plain text display.
 - The countdown to the time remaining is visible in the right digital display.
 - The  symbol illuminates.

When the set duration is up:

- A sequence of 5 short acoustic signals is repeated for 1 minute.
- «Timer» «finished» appears in the plain text display.
- The  symbol flashes.





Press the  button to switch off the acoustic signal.

Checking and changing

- ▶ Press the  button.
 - «Timer: set mins./secs.» « 0'00: press again» appears in the plain text display.
 - The countdown to the time remaining flashes in the right digital display.
 - The  symbol flashes.

Turn the  adjusting knob to change the timer duration.







Switching off before time

- ▶ Press the  button 2×.
 - «Timer: set mins./secs.» appears in the plain text display.
 -  flashes in the right digital display.
 - The  symbol flashes.
- ▶ Press the  adjusting knob to confirm.



5.3 Operating time

The operating mode selected automatically switches off when the operating time is up.

Setting

- Select the desired operating mode and cooking space temperature.
- Preheat the cooking space if necessary.
- Place the food in the cooking space.
- Press the  button.
 - «Operating time hrs./mins.» « Switch-off time: press again» appears in the plain text display.
 -  flashes in the right digital display.
 - The  symbol flashes.
- Turn the  adjusting knob to set the duration (maximum of ).

Checking and changing



- Press the  button.
 - The time remaining flashes in the right digital display.
 - The  symbol flashes.

Turn the  adjusting knob to change the duration.

Switching off before time

- ▶ Press the  button.

End of the operating time

- The operating mode selected switches off automatically when the operating time is up.
- A long, intermittent acoustic signal is emitted for 1 minute.
- «Operating time finished»  Continue: select duration» appears in the plain text display.
- The cooking space temperature appears in the left digital display.
-  flashes in the right digital display.
- The I→I symbol flashes.
- The settings remain for 3 minutes.

Extending the operating time

- ▶ Turn the  adjusting knob within 3 minutes to select a new duration.

Switching off

- ▶ Press the  button.
 - The settings are cleared.
 - The residual heat appears in the left digital display.

5.4 Delayed start

The delayed start is activated when for the operating mode selected both an operating time and a switch-off time are set. The appliance switches automatically on and off again at the desired times.

If you use the food probe, you will need to estimate the duration. You will find a guide on times in **TIPS ON SETTINGS**. The appliance will automatically switch on with a delay and off again when the set food probe temperature is reached. Note that, depending on the estimated duration, this could occur somewhat earlier or later than the set switch-off time.









A delayed start is not possible for programmes «BakeOmatic»/«GourmetSteam»/«Recipes» and «Own recipes» that require the appliance to be preheated.





Perishables should not be kept unrefrigerated.

- Place the food in the cooking space.
- Select the desired operating mode and cooking space temperature.



Setting the operating time

- Press the  button.
 - «Operating time hrs./mins.» « Switch-off time: press again» appears in the plain text display.
 -  flashes in the right digital display.
 - The  symbol flashes.
- Turn the  adjusting knob to set the duration (maximum of ).

Setting the switch-off time

- ▶ Press the  button again.
 - «Switch-off time» « Duration: press again» appears in the plain text display.
 - Switch-off time – without a delayed start – e.g.  flashes in the right digital display.
 - The  symbol flashes.
- ▶ Turn the  adjusting knob to set the switch-off time.



 The switch-off time can be delayed by a maximum of 23 hours and 59 minutes. If the «12 h» time format has been selected, the switch-off time can be delayed by a maximum of 11 hours and 59 minutes.

- ▶ Press the  adjusting knob to confirm.
 - The time appears in the right digital display.
 - The  symbol illuminates.
 - The operating mode selected remains switched off until the automatic start.

Example: ▶ Select the  operating mode and 180 °C.

- ▶ At 8:00, set an operating time of 1 hour and 15 minutes.
- ▶ Set the switch-off time to 11:30.
 - The appliance will automatically switch on at 10:15 and off again at 11:30.

Checking and changing



- ▶ Press the  button 1×.
 - The operating time is visible for 3 seconds.
- ▶ Press the  button 2×.
 - The switch-off time flashes. It can be changed.

 The operating time, the operating mode and the cooking space temperature cannot be changed.

Switching off before time

- Press the  button.

End of the operating time

- The operating mode selected switches off automatically when the operating time is up.
- A long, intermittent acoustic signal is emitted for 1 minute.
- «Operating time finished»  Continue: select duration» appears in the plain text display.
- The cooking space temperature appears in the left digital display.
-  flashes in the right digital display.
- The I→I symbol flashes.
- The settings remain for 3 minutes.

Extending the operating time



- Turn the  adjusting knob within 3 minutes to select a new duration.

Switching off

- Press the  button.
 - The settings are cleared.
 - The residual heat appears in the left digital display.

6 Operating modes



- Follow the advice in TIPS ON SETTINGS and in TIPS AND TRICKS!
- Press the  button once or more to select the desired operating mode.

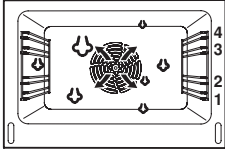
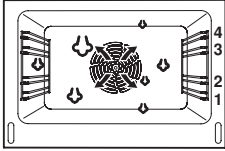
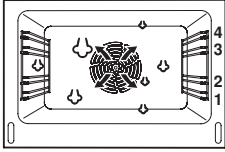

Operating mode	Symbol	Temperature range	Recommended temperature	Level
Steaming		30-100 °C	100 °C	1-4
Regenerating		100-150 °C	120 °C	1-4
Professional baking		100-230 °C	210 °C	2 1+3

- Place tins, moulds, etc. on the wire shelf.
- Always push the «sloped» side of the original baking tray right to the back of the cooking space.

Use	Heating method
<p>Cooking vegetables, rice, cereal products, pulses and egg dishes. Poaching meat, poultry and fish. Extracting juice from fruit and berries. Making yogurt and preserves. Place the stainless steel tray underneath the perforated cooking tray.</p>	<p>The cooking space is heated simultaneously by steam and hot air. The food is heated up or cooked by steam</p> 
<p>Heating up pre-cooked food and frozen and convenience products. Simultaneously regenerating food on several levels.</p>	<p>The cooking space is heated by steam and hot air. The food is reheated gently without drying it out.</p> 
<p>Bread, yeast pastries, puff pastries (fresh or frozen) on 1 or 2 levels. Put the food in the cold cooking space.</p>	<p>The cooking space is heated in a first phase by steam and is automatically followed in a second phase by hot air.</p> 

6 Operating modes

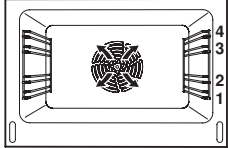
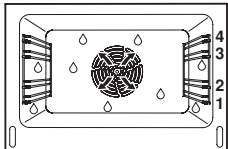
Operating mode	Symbol	Temperature range	Recommended temperature	Level
Hot air		30-230 °C	180 °C	2 1+3
Hot air humid		30-230 °C	180 °C	2 1+3
Hot air + steaming		30-230 °C	180 °C	2 1+3

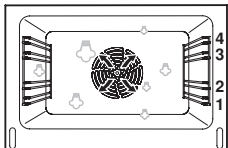
Use	Heating method
<p>Cakes, biscuits, bread and roasts on 1 or 2 levels.</p>	<p>A heating element behind the back wall of the cooking space heats up the air inside the cooking space and which is circulated evenly.</p> 
<p>Gratins, soufflés, bread and yeast pastries on 1 or 2 levels.</p>	<p>A heating element behind the back wall of the cooking space heats up the air inside the cooking space and which is circulated evenly. The steam produced is largely retained in the cooking space ensuring the food retains its moisture.</p> 
<p>Gratins, soufflés, meat, frozen products, chestnuts, puff pastries, yeast pastries, bread and convenience foods on 1 or 2 levels.</p> <p>Press the  button to activate/deactivate steam.</p> <p>The  symbol is illuminated when steam is activated.</p>	<p>A heating element behind the back wall of the cooking space heats up the air inside the cooking space and which is circulated evenly. To improve the energy transfer to the food, activate steam.</p> <p>Steam over 100 °C is not visible.</p> 

7 Food probe



Only use the food probe supplied. Do not clean the food probe in the dishwasher.

7.1 Positioning the food probe

- Insert the food probe **1** into the meat so that the tip is in the centre of the thickest part. The food probe **1** must as far as possible be completely covered by the meat in order to get a correct reading.

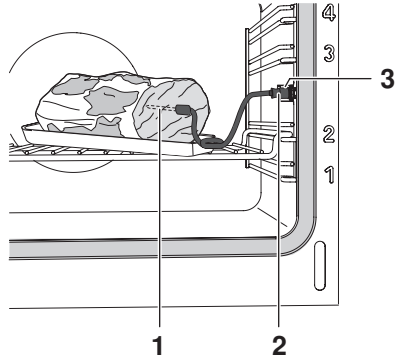

Reliable readings are only possible for thick, compact cuts of the meat; if necessary, tie the meat up.

Do not position the food probe next to a bone or in fat.

With poultry, the food probe should be inserted into the inside of the leg.

The socket **3** for the food probe is on the right-hand side wall of the cooking space. Both the plug and the socket are without current.

- Always keep the plug **2** clean.
- Flip back the cover and insert the plug **2** into the socket **3**.

7.2 Food probe temperature



The food probe has to be plugged in order to set the food probe temperature.

The food probe temperature depends on the cut of meat and the desired level of doneness.

Follow the advice given in TIPS ON SETTINGS.

Setting

- Select the desired operating mode and cooking space temperature.
- Press the °C button 1×.
 - flashes in the left digital display.
 - The symbol flashes.
- Turn the adjusting knob to set the food probe temperature.
- Press the adjusting knob to confirm.
 - The actual food probe temperature is displayed during the cooking process.

As long as the food probe temperature is below 30 °C,

- appears in the left digit display.

Checking and changing

- Press the °C button 2×.
 - The set food probe temperature flashes in the left digital display.
 - The symbol flashes.

Turn the adjusting knob to change the food probe temperature.

End of cooking

- The appliance switches off automatically when the food probe temperature set is reached.
- An acoustic signal is emitted for 1 minute.
- «Food probe temperature reached» appears in the plain text display.
- The actual food probe temperature, e.g. **70°C**, appears in the left digital display.
- The **Λ** symbol flashes.
- Press the **○** button to switch off the appliance.



If the meat is left in the cooking space after having switched off the appliance, the food probe temperature will continue to rise due to the residual heat.

Measuring the food probe temperature

- Select the desired operating mode and cooking space temperature.
- Press the **°C** button 1x.
 - **--** flashes in the left digital display.
 - The **Λ** symbol flashes.
- Press the **OK** adjusting knob to confirm.
 - The actual food probe temperature is displayed during the cooking process.

As long as the food probe temperature is below 30 °C,

- **--** appears in the left digital display.



The operating mode must be switched off manually:
Press the **○** button or set the operating time.

8 Soft roasting

The «soft roasting» setting enables you to carefully roast quality cuts of meat. The end of cooking can be set precisely, dependent on the weight and thickness of the meat. The cooking duration can be set between 2½ to 4½ hours. The cooking space temperature is automatically regulated.

Tips for an optimal result

- Weight of meat: 500–2000 g
- Meat thickness: at least 4 cm
- Quality: lean, quality meat with few sinews

Preparing the meat

- Season or marinate.



Remove traces of marinades with herbs, mustard etc. before searing. These constituents easily burn.

- Salt the meat immediately before searing.
- Briefly sear the meat on all sides. Do not exceed a searing time of 5 minutes.
- Then place the meat in a glass or porcelain roasting dish.

Positioning the food probe

- Insert the food probe in to the meat so that the tip is in the centre of the thickest part.



The food probe must as far as possible be completely covered by the meat.

The temperature measured by the food probe in the meat is important in order that the meat is optimally cooked on completion of the cooking.

- Put the wire shelf at level 2 and place the roasting dish on it.
- Insert the plug of the food probe into the socket.

Selecting and starting «Soft roasting»

















Selecting and starting the «Soft roasting» programme is explained using «Soft roasting» «Leg of lamb» as an example.





The longer the meat is roasted, the more tender and succulent it becomes. This is especially so with thick cuts of meat.

The values cannot be adjusted after the start.



Pay attention to the information under TIPS ON SETTINGS.

- ▶ Press the  adjusting knob to activate the plain text display.
 - «Select  and press OK» «BakeOmatic» appears in the plain text display.
- ▶ Turn the  adjusting knob until «Select  and press OK» «Soft roasting» appears in the plain text display.
- ▶ Press the  adjusting knob to confirm.
 - «Soft roasting» «Fillet of veal» appears in the plain text display.
- ▶ Turn the  adjusting knob until «Soft roasting» «Leg of Lamb» appears in the plain text display.
- ▶ Press the  adjusting knob to confirm.
 - «Leg of Lamb» «rare» appears in the plain text display.
- ▶ Press the  adjusting knob to confirm.
 - «Leg of Lamb» «Start» appears in the plain text display.
 - The preset food probe temperature  appears in the left digital display.
 -  indicating an operating time of 3½ hours appears in the right digital display.
 - The  /  and  symbols illuminate.
- ▶ Press the  adjusting knob to confirm.
 - «Soft roasting» starts.
 - The actual food probe temperature appears in the left digital display.
 - The actual operating time appears in the right digital display.
 - The  /  and  symbols illuminate.



Changing the food probe temperature

- Press the °C button.
 - The recommended food probe temperature **63°C** flashes in the left digital display.
 - The  symbol flashes.
- Turn the  adjusting knob to change the food probe temperature.

Changing the operating time

- Press the  button.
 - **3h 30** flashes in the right digital display.
 - The  symbol flashes.
- Turn the  adjusting knob to change the operating time.

Inadvertently interrupting the programme

- If the  button is pressed, operation is interrupted.
 - «Leg of lamb» «continue» appears in the plain text display.
- Press the  adjusting knob to continue operation.

Switching off before time

- Press the  button 2x.

9 BakeOmatic

BakeOmatic comprises programmes for 14 different food groups (A1–A14). BakeOmatic detects the amount, shape and consistency of the food. The duration and cooking space climate are automatically adapted to the particular food. BakeOmatic is suitable for any recipes.

9.1 Degree of browning

The degree of browning can be adjusted to by selecting the «lightly browned», «medium browned» or «well browned» setting.

9.2 Cooking/Baking times

When BakeOmatic starts, sensors determine optimum and exact cooking or baking times. The effective cooking or baking times are displayed after about 5–10 minutes.



Before starting, the cooking space must have cooled down in order to determine the optimum cooking or baking time.

In order to determine the duration correctly, the appliance door must not be opened when **h** is flashing in the right digital display.

For frozen products, select the approximate cooking or baking time instead of the degree of browning as frozen products are processed differently.

Follow the advice given in TIPS ON SETTINGS.

Recipes requiring preheating

Example: «A14 Torte»

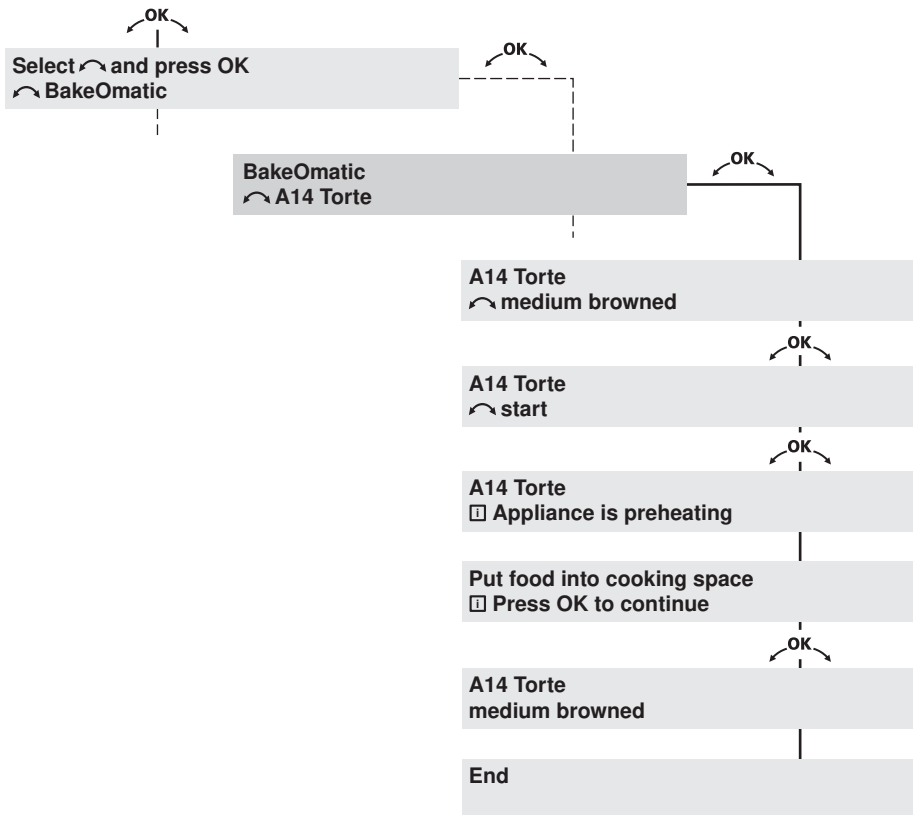

9.3 Selecting and starting BakeOmatic













Before starting, the cooking space must have cooled down in order to determine the optimum cooking or baking time.

For the programme «BakeOmatic» the filled water container must be installed in the compartment provided.

For programmes that do not require preheating, place the food in the cold cooking space.

Preparing for, selecting and starting BakeOmatic is demonstrated using «A14 Torte» as an example.

- ▶ Using your own recipe, prepare the dough for the torte.
- ▶ Press the  adjusting knob to activate the plain text display.
 - «Select  and press OK» «BakeOmatic» appears in the plain text display.
- ▶ Press the  adjusting knob to confirm.
 - «BakeOmatic» «A1 Fresh aperitif nibbles» appears in the plain text display.
- ▶ Turn the  adjusting knob until «BakeOmatic» «A14 Torte» appears in the plain text display.
- ▶ Press the  adjusting knob to confirm.
 - «A14 Torte» «medium browned» appears in the plain text display.
- ▶ Turn the  adjusting knob to change the degree of browning, if necessary.
- ▶ Press the  adjusting knob to confirm.
 - «A14 Torte» « Appliance is preheating» appears in the plain text display.
 - The cooking space is preheating.
 - A single acoustic signal is emitted as soon as the cooking space temperature is reached
 - «Put food into cooking space» «Press OK to continue» appears in the plain text display.
- ▶ Put the dough for the torte (your own recipe) in a cake tin, place on the wire shelf and put in the cooking space at the level given in the recipe.

- ▶ Press the  adjusting knob to confirm.
 - The appliance starts with the corresponding settings.
 -  and  appear in the right digital display.
 - The cooking or baking time is being determined.



In order to determine the cooking or baking time correctly, the appliance door must not be opened when  is flashing in the digital display.

- The effective cooking or baking time subsequently appears in the right digital display.

Switching off before time

- ▶ Press the  button 2×.

10 GourmetSteam

Press the  adjusting knob to access and start stored recipes. A recipe consists of several steps that once started run automatically.

The recipes are detailed in the recipe book. After being selected, a stored recipe can be changed if required.

Recipes requiring preheating

Example: «G16 Chocolate surprise»

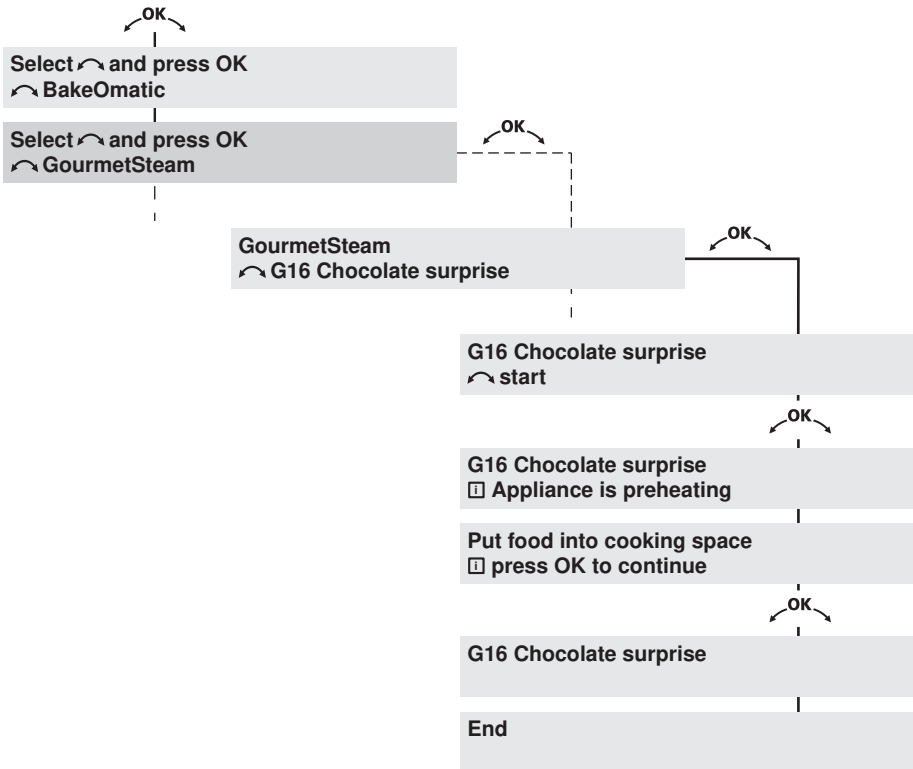











10.1 Selecting and starting GourmetSteam



For the programme «GourmetSteam» the filled water container must be installed in the compartment provided.

For recipes that do not requiring preheating, place the food in the cold cooking space.

Preparing for, selecting and starting GourmetSteam is demonstrated using «G16 Chocolate surprise» as an example.

- Prepare the chocolate surprise following the recipe in the recipe book.
- Press the  adjusting knob to activate the plain text display.
 - «Select  and press OK» «BakeOmatic» appears in the plain text display.
- Turn the  adjusting knob until «Select  and press OK» «GourmetSteam» appears in the plain text display.
- Press the  adjusting knob to confirm.
 - «GourmetSteam» «G1 Farmhouse soup» appears in the plain text display.
- Turn the  adjusting knob until «GourmetSteam» «G16 Chocolate surprise» appears in the plain text display.
- Press the  adjusting knob to confirm.
 - «G16 Chocolate surprise» « Appliance is preheating» appears in the plain text display.
 - The cooking space is being preheated.
 - A single acoustic signal is emitted as soon as the preset cooking space temperature is reached.
 - «Put food into cooking space» « press OK to continue» appears in the plain text display.
- Place the ramekins on the stainless steel tray.
- Put the stainless steel tray at level 2 in the cooking space.
- Press the  adjusting knob to confirm.
 - The appliance starts with the corresponding settings.

Checking and making temporary changes



Settings can be adapted.

The stored recipes are only changed temporarily – the next time the recipes are accessed they appear in their original form.



To change the cooking space temperature

- Press the °C button.
- Turn the  adjusting knob to change the cooking space temperature.

To change the operating time

- Press the  button.
- Turn the  adjusting knob to change the operating time.

Inadvertently interrupting the programme

- If the  button is pressed, operation is interrupted.
 - «G16 Chocolate surprise» «continue» appears in the plain text display.
- Press the  adjusting knob to continue operation.

Switching off before time

- Press the  button 2x.

11 Recipes

Press the **OK** adjusting knob to access and start stored recipes. A recipe can consist of several steps that once started run automatically.

The recipes are detailed in the recipe book. After being selected, a stored recipe can be changed if required.



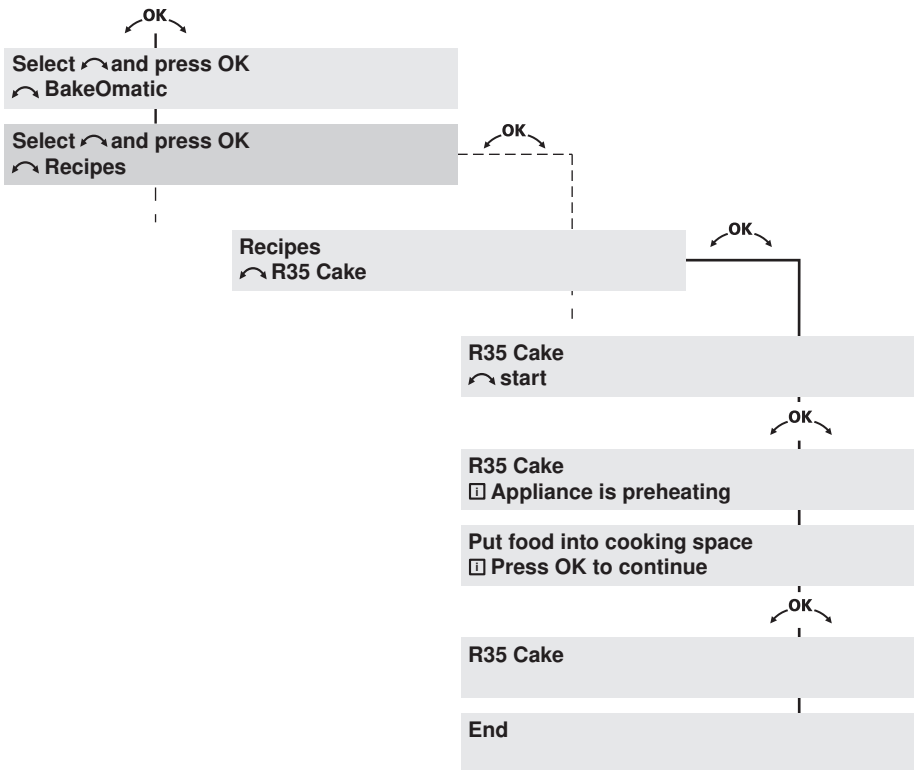

Recipes requiring preheating

Example: «R35 Cake»













11.1 Selecting and starting a recipe



For operating modes «with steam» , , , and  the filled water container must be installed in the compartment provided.

For recipes that do not requiring preheating, place the food in the cold cooking space.

Preparing, selecting and starting a recipe is demonstrated using «R35 Cake» as an example.

- ▶ Prepare the cake following the recipe in the recipe book.
- ▶ Press the  adjusting knob to activate the plain text display.
 - «Select  and press OK» «BakeOmatic» appears in the plain text display.
- ▶ Turn the  adjusting knob until «Select  and press OK» «Recipes» appears in the plain text display.
- ▶ Press the  adjusting knob to confirm.
 - «Recipes» «R1 Aperitif nibbles» appears in the plain text display.
- ▶ Turn the  adjusting knob until «Recipes» «R35 Cake» appears in the plain text display.
- ▶ Press the  adjusting knob to confirm.
 - «R35 Cake» «start» appears in the plain text display.
- ▶ Press the  adjusting knob to confirm.
 - «R35 Cake» «Appliance is preheating» appears in the plain text display.
 - The cooking space is preheating.
 - A single acoustic signal is emitted as soon as the preset cooking space temperature is reached.
 - «Put food into cooking space» « Press OK to continue» appears in the plain text display.
- ▶ Put the wire shelf at level 2 in the cooking space.
- ▶ Put the cake tin on the wire shelf.
- ▶ Press the  adjusting knob to confirm.
 - The appliance starts with the corresponding settings.

Checking and making temporary changes

Settings can be adapted.

The stored recipes are only changed temporarily – the next time the recipes are accessed they appear in their original form. Once started, only the current step can be changed.

To change the cooking space temperature

- Press the °C button.
- Turn the ↶^{OK}↷ adjusting knob to change the cooking space temperature.

To change the operating time

- Press the ⊖ button.
- Turn the ↶^{OK}↷ adjusting knob to change the operating time.

Inadvertently interrupting the programme

- If the ○ button is pressed, operation is interrupted.
 - «R35 Cake» «continue» appears in the plain text display.
- Press the ↶^{OK}↷ adjusting knob to continue operation.

Switching off before time

- Press the ○ button 2x.

12 Own recipes

10 of your own favourite recipes can be stored. A recipe can consist of several steps, operating modes and operating times that once started run automatically. Press the  adjusting knob to access and start stored recipes.

12.1 Creating own recipes







If using the food probe, please observe the following:







- ▶ Enter an estimated duration.
 - The programme step is the amount of time it takes to reach the set food probe temperature.

Making recipe settings





If using the food probe, it must be plugged in before entering the settings for the recipe.

- ▶ Press the  adjusting knob to activate the plain text display.
 - «Select  and press OK» «BakeOmatic» appears in the plain text display.
- ▶ Turn the  adjusting knob until «Select  and press OK» «Own recipes» appears in the plain text display.
- ▶ Press the  adjusting knob to confirm.
- ▶ Turn the  adjusting knob until the first empty recipe appears in the plain text display.
 - Example: «Own recipes» «Recipe 1 (empty)» appears in the plain text display.







- Press the  adjusting knob to confirm.
 - «Recipe 1 (empty)» «change» appears in the plain text display.
- Press the  adjusting knob to confirm.
 - «Step 1» appears in the plain text display.
- Set the desired operating mode, cooking space temperature, food probe temperature and operating time for step 1.
- Press the  adjusting knob to confirm.
- Turn the  adjusting knob and select step 2.
- Set the desired operating mode, cooking space temperature, food probe temperature and operating time for step 2.
- Set additional steps in the same way.
- Press the  adjusting knob to confirm.
- Press the  adjusting knob again to confirm.
 - «Recipe 1 (empty)» «save» appears in the plain text display.

You can now save, change or copy the recipe or start it immediately without saving it.

- Turn the  adjusting knob until the desired option appears in the plain text display.
- Press the  adjusting knob to confirm.

Copying a recipe

Each recipe that is stored – from the recipe book with a R number as well as your own recipes – can be copied and changed.



- ▶ Press and turn the  adjusting knob to select the recipe that is to be copied.
- ▶ Press the  adjusting knob to confirm.
- ▶ Turn the  adjusting knob until «copy» appears in the plain text display.
- ▶ Press the  adjusting knob to confirm.
- ▶ Turn the  adjusting knob until the desired (empty) storage space appears.
- ▶ Press the  adjusting knob to confirm.
 - The recipe is saved.



A storage space that is already being used can be overwritten.

Clearing a recipe

Any and all recipes in «Own recipes» can be deleted.

- ▶ Press and turn the  adjusting knob to select the recipe that is to be deleted.
- ▶ Turn the  adjusting knob until «clear» appears in the plain text display.
- ▶ Press the  adjusting knob to confirm.
 - The recipe is deleted.
 - The standard name, e.g. «Recipe 1 (empty)», appears in the plain text display.







13 Keeping cooked food warm

Press the  adjusting knob to access and start the «Keep warm» function. It can be used to keep cooked food warm.



If the cooking space is already hot, open the appliance door and allow the cooking space to cool down for 3 to 4 minutes before starting the «Keep warm» function. This ensures that the food does not overcook.

Switching on

- ▶ Press the  adjusting knob to activate the plain text display.
 - «Select  and press OK» «BakeOmatic» appears in the plain text display.
- ▶ Turn the  adjusting knob until «Select  and press OK» «Keep warm» appears in the plain text display.
- ▶ Press the  adjusting knob to confirm.
 - «Keep warm» «Start» appears in the plain text display.
- ▶ Press the  adjusting knob to confirm.



To maintain the desired degree of doneness, select an operating time of under 1½ hours.

14 Tips and tricks

Steaming

- When steaming, a variety of food can be cooked at the same time. For example, rice or pulses can be prepared at the same time as vegetables with similar cooking times, saving energy and the washing-up.
- Grains (e.g. rice and millet) and pulses (e.g. lentils), adding an appropriate amount of liquid, can be cooked directly in suitable tableware.







Type of food	Weight	Approximate amount of liquid to be added (depending on desired consistency)
Rice	100 g	1 ½ dl salted water, bouillon, etc.
Risotto	100 g	2 ½ dl water, wine (to taste)
Maize semolina (polenta)	100 g	3 dl water/milk mixture
Semolina	100 g	2–3 dl water
Lentils	100 g	2–3 dl water
Ebly wheat	100 g	1–1 ½ dl water
Millet	100 g	1 ½–2 dl water
Chickpeas, soaked	100 g	½–1 dl water

- When steaming, always place the stainless steel tray underneath the perforated cooking tray or wire shelf to catch food spills and collect condensate.
- Put the tableware directly on the stainless steel tray or the wire shelf.

Warm, moist cloths

Warm, moist cloths can be a pleasant way to clean hands after a meal.

- Spread clean, moist towelling cloths across the perforated cooking tray.
- Select the following settings:

	°C		 mins.		
	80	no	ca. 5	2	

Hot air

Baking and roast

Result

- The baking or roast looks good on the outside but is still doughy or raw on the inside.

Solution

- Next time, set a lower cooking space temperature and lengthen the operating time.

Regenerating

Result

- Regenerated food is dried out
- Too much condensate on or around the regenerated food.

Solution





- Next time, set a lower cooking space temperature and shorten the operating time.
- Next time, set a higher cooking space temperature and lengthen the operating time.

Professional baking

- After shaping, allow bread, bread buns and other yeast cakes and pastries to proof briefly. 10 minutes is usually sufficient. Place the dough on the stainless steel tray, which has been lined with baking paper, put it into the unheated cooking space and bake using the  operating mode.
- A nice, shiny crust is formed during professional baking. Yeast pastries and puff pastries do not need to be brushed with egg yolk or cream.
- The appliance door should not be opened during the steaming phase. The streaming in of cold air will prolong the steaming phase and the bread can be oversteamed. The bread will come out flatter.
- For a nice, crispy crust: the smaller the item to be baked, the higher the temperature should be during the hot air phase. The optimum baking temperature for bread buns is generally higher than for a single loaf of bread.

Hot air + steaming





Through the condensation of steam, the transfer of energy to the food is more efficient than with baking with hot air. This speeds up the cooking process. The food retains its own moisture and delicate parts do not burn so quickly. This operating mode is particularly suitable for food with a crunchy top, e.g. gratins, braised meat, frozen ready-made products such as spring rolls, potato products, etc.

- Press the  button to deactivate steam.
 - The  symbol goes out.
- Press the  button to activate steam.
 - The  symbol illuminates.

Cakes

Result	Solution
<ul style="list-style-type: none"> The cake collapses. 	<ul style="list-style-type: none"> ▶ Check settings with those given in TIPS ON SETTINGS. ▶ Next time, set a lower cooking space temperature and lengthen the operating time. ▶ Stir the cake mixture well. When finished, bake immediately. ▶ For whisked sponges, beat the egg yolks/ egg whites to a foam and then carefully fold into the mixture. When finished, bake immediately. ▶ Follow instructions on how much baking powder to add.

Uneven browning

Result	Solution
<ul style="list-style-type: none"> The baking has browned unevenly. 	<ul style="list-style-type: none"> ▶ Next time, set a lower the cooking space temperature and adjust the operating time. ▶ If using , ,  or , check that the levels used correspond to those recommended in TIPS ON SETTINGS. ▶ Do not push baking tins or bulky foodstuff right to the back of the cooking space.
<ul style="list-style-type: none"> The baking has come out lighter on one baking tray than on the other. 	<ul style="list-style-type: none"> ▶ Check that the settings used correspond to those recommended in TIPS ON SETTINGS'



Some uneven browning is normal. More even browning is generally achieved at lower cooking space temperatures.



14.1 Hygiene

Press the  adjusting knob to access and start the stored programmes.

The following programmes are available for selection:

- «Sterilise baby bottles» replaces the need to boil baby bottles in hot water.
- «Prepare jam jars» replaces the need to prepare empty jam jars by rinsing them with hot water.
- «Preserve jam» helps to preserve the jam for longer.

14.2 Saving energy

The  operating mode consumes comparatively less energy than the  operating mode.

- Avoid opening the appliance door frequently.
- Only switch the illumination on if needed.
- Use the residual heat: for longer cooking times, i.e. over 30 minutes, switch the appliance off some 5 to 10 minutes before the end of the cooking time. Exceptions: soufflé, sponge, choux pastry and puff pastry.
- Minimise preheating.
- Only preheat the cooking space if the baking results depend on it.



To reduce power consumption to an absolute minimum, select «Time display» «invisible» in the user settings. Despite automatic energy-saving stand-by, all safety functions are active. All displays go out when the cooking process has been completed.

15 Descaling

Whenever steam is produced, depending on the hardness of the local water supply (i.e. the limescale content of the water), limescale is deposited in the boiler.

The appliance automatically recognises when descaling is necessary.

– «Boiler scaled up,» «please descale!» appears in the plain text display.

The time interval between descaling depends on the hardness of the water and frequency of use. If steaming 4× 30 minutes per week, the appliance must be descaled – depending on water hardness – roughly as follows:

Water hardness	Descal after about
• Hard	6 months
• Medium	9 months
• Soft	18 months



Descaling takes about 45 minutes.

We recommend you descale the appliance whenever the warning appears in the plain text display.

Failure to descale the appliance will likely impair the functioning of or cause damage to the appliance.

15.1 Operating time remaining to descaling

The operating time remaining for steaming until the next descaling can be determined by pressing the  adjusting knob and under «Descaling» «Time to descaling xxh».

Durgol swiss steamer decalcifier



The descaler contains highly effective acid. Rinse away any splashes immediately with water. Follow the manufacturer's instructions.



For descaling, only use the special descaler developed for this appliance and which is available at all good chemists. This special descaler enables you to achieve a gentle yet professional level of descaling.

Standard descaling solutions are not suitable as they may contain foam-creating additives or not be effective enough.







Using a different descaler could cause:

- Overfoaming in the cooking space
- Insufficient descaling of the boiler
- Damage to the appliance in the worst case.

Descaling



The appliance must be switched off. The appliance door must be closed when descaling is being carried out. Burns hazard! For safety reasons, once started the descaling process cannot be aborted.

- ▶ Press the  adjusting knob to activate the plain text display.
- ▶ Turn the  adjusting knob until «Descale» appears.
- ▶ Press the  adjusting knob to confirm.
 - «Descale» «Descale appliance» appears in the plain text display.
- ▶ Press the  adjusting knob to confirm.
 - «Descale appliance» «start» appears in the plain text display.
- ▶ Press the  adjusting knob to confirm.
 - «Add 0.5 l descaler» «and press OK» appears in the plain text display.
- ▶ Pour the entire contents of the special descaler undiluted into the water tank.
- ▶ Slot the water tank into position in the water tank compartment.
- ▶ Press the  adjusting knob to confirm.
 - The descaling phase starts.
 - «Descale appliance» «running» appears in the plain text display.

After about 30 minutes, «Pour away descaler» «Add 1 l water» appears in the plain text display.

- ▶ Remove the water tank, pour away the descaler and fill the tank with 1 l cold water.
- ▶ Put the water tank back.
 - The rinsing phase starts automatically.
 - «Descale appliance» «1st rinsing cycle» appears in the plain text display.



Whether further rinsing cycles are required depends on the level of soiling of the liquid being pumped off.

- In this case, «Descale appliance» «Repeat 1st rinsing cycle» appears in the plain text display.

- ▶ As soon as «Pour away water» «Add 1 l water» appears in the plain text display, remove the water tank, empty the water and refill the tank with cold water.
- ▶ Put the water tank back.
 - The rinsing phase starts automatically.
 - «Descal appliance» «2nd rinsing cycle» appears in the plain text display.







Whether further rinsing cycles are required depends on the level of soiling of the liquid being pumped off.

- In this case, «Descal appliance» «Repeat 2nd rinsing cycle» appears in the plain text display.

- ▶ When the 2nd rinsing phase is over, «Pour away water» «Descaling completed» appears in the plain text display.
- ▶ Remove, empty and dry the water tank.
- ▶ Wipe up any water in the bottom of the cooking space with a soft cloth.



For the  /  /  and  operating modes, after descaling the water that is pumped back into the water tank at the end of cooking may not be clear. This will not affect the cooking or baking characteristics nor the quality of the food being cooked or baked.

16 Care and maintenance



Allow the appliance and accessories to cool down before cleaning. Do not use abrasive, caustic cleaning agents or stainless steel cleaner. Do not use abrasive scouring pads, steel wool, etc. as such products can damage the surface.

Whilst the message «  Do not remove water tank» shows in the plain text display, do not place your hands in the water tank compartment. Scalding hazard.

16.1 Cleaning the exterior

- Remove any soiling or excess cleaning solution immediately.
- Clean the surface with a soft cloth dampened with water and a little washing-up liquid – for metallic surfaces rub in the direction of the original polish lines. Dry with a soft cloth.
- Clean the appliance door with a soft cloth dampened with water and a little washing-up liquid. Dry with a soft cloth.

16.2 Cleaning the appliance door

- ▶ Clean the appliance door with a soft cloth dampened with water and a little washing-up liquid. Dry with a soft cloth.

Removing the appliance door



Exercise caution when removing and reassembling the appliance door. It weighs approximately 8 kg. Risk of injury!

- ▶ Open the appliance door as far as it will go.
- ▶ Fold the clamps **2** on the door hinges **1** forward.

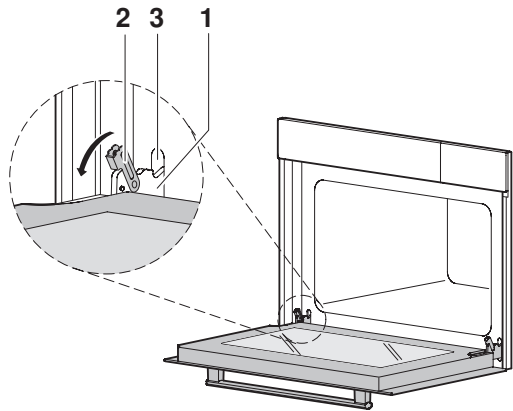

- ▶ Close the appliance door as far as its at-rest position (approximately 30°).
- ▶ Lift the appliance door forward and out.

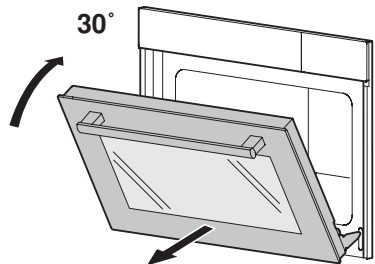

Reassembling the appliance door

- ▶ From the front, push the two hinges **1** into the opening **3**.
- ▶ Open the appliance door as far as it will go and close back the clips **2**.

16.3 Removing the shelf guides

- ▶ Unscrew the knurled nuts **1** in the front of the shelf guides in an anti-clockwise direction.
- ▶ Pull the shelf guides **2** to the side of the screws and remove from the front.

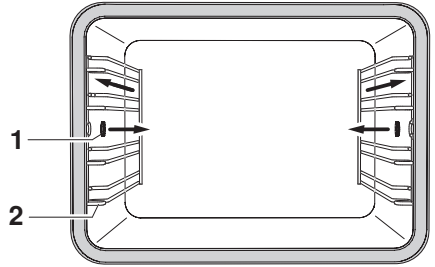

Reassembling the shelf guides

- ▶ Insert the shelf guides into the openings in the back wall of the cooking space and position on the screws. Place the knurled nuts on the screws and tighten securely in a clockwise direction.

16.4 Replacing the door seal

For safety reasons, the door seal must be replaced by our Customer Services.

16.5 Cleaning the accessories



Do not clean either the food probe or the water tank in the dishwasher.

- The stainless steel tray, the perforated cooking tray, the wire shelf and the shelf guides can be cleaned in the dishwasher.
- Although the original cake tray can be washed in a dishwasher, this will reduce the TopClean non-stick effect.
- Watermarks in the water tank can be removed using a standard descaler.
- ▶ If the water tank valve drips, descale it.

16.6 Cleaning the cooking space



Do not bend temperature sensor during cleaning.

Do not use abrasive cleaning agents. Do not use abrasive scouring pads, steel wool, etc. as such products can damage the surface.

- ▶ Any condensate or food in the cooking space – after each cooking session with steam – must be dried completely or removed.
- ▶ Wipe the cooking space clean while still warm using a soft cloth dampened with soapy water. Polish dry with a soft cloth.
- ▶ To remove dried-on soiling easier, switch the appliance on for a short period of time (about 30 minutes) beforehand, setting it to the  operating mode and a temperature of 80 °C. This will soften the soiling.



With use, the cooking space will over time turn a golden colour. This discolouration is a normal property of stainless steel and affects neither the cooking or baking properties of the appliance nor its operation.

Blue tarnish spots and condensate residue can be easily removed using a mild acidic cleaning agent or some lemon juice.

16.7 Replacing a defective light bulb

For safety reasons, in case of a defective light bulb please contact our Customer Services.

17 Troubleshooting

This section lists faults that can be solved simply by following the instructions given. If another fault is displayed or the fault cannot be remedied, please call Customer Services.



Please note down the error message in full (message, serial number (FN) and error number (E)) before calling Customer Services. As an example:

**FX / EXX see instructions
FN XXX XXXXXX**

17.1 What to do if ...

... the appliance is not working and the displays are not illuminated

Possible cause	Solution
<ul style="list-style-type: none">The fuse or circuit breaker for electrical installations in the home is defective.	<ul style="list-style-type: none">➤ Change the fuse.➤ Reset the circuit breaker.
<ul style="list-style-type: none">The fuse or circuit breaker keeps blowing.	<ul style="list-style-type: none">➤ Call Customer Services.
<ul style="list-style-type: none">An interruption in the power supply.	<ul style="list-style-type: none">➤ Check the power supply.

... the illumination is not working

Possible cause	Solution
<ul style="list-style-type: none">The light bulb is defective.	<ul style="list-style-type: none">➤ Call Customer Services.

... the appliance starts making noises during operation

Possible cause	Solution
<ul style="list-style-type: none"> The appliance may emit noise during operating (e.g. switching and pumping noises). 	<p>Such noise is normal. No action needed.</p>

... **XXX**
 Fill water tank **appears**

Possible cause	Solution
<ul style="list-style-type: none"> The water tank is empty. 	<p>► Fill the water tank and slot it into position in the water tank compartment.</p>

... **XXX**
 Do not remove water tank **appears**

Possible cause	Solution
<ul style="list-style-type: none"> For safety reasons, the water in the boiler is not pumped off until the temperature of the water drops below 80 °C. 	<p>If there is enough cold water in the water tank, the boiler will be automatically filled. This will cool down the water in the boiler. If there is not enough cold water in the water tank, it will take longer to cool down (this can take up to 30 minutes). The appliance may be used without further ado.</p>

... **Boiler scaled up,
please descale!** **appears**

Possible cause	Solution
<ul style="list-style-type: none"> The boiler in the appliance is scaled up. 	<ul style="list-style-type: none"> ➤ Start descaling.

... **Appliance blocked,
descaling necessary** **appears**

Possible cause	Solution
<ul style="list-style-type: none"> Used unsuitable descaler. 	<ul style="list-style-type: none"> ➤ Descale again using the recommended descaler.
<ul style="list-style-type: none"> Descaling unsuccessful. 	<ul style="list-style-type: none"> ➤ If the message does not disappear after repeating the descaling process several times, note down the error message in full (message, serial number (FN) and error number (E)). ➤ Call Customer Services.



... **FX / EXX see instructions
FN XXX XXXXXX** **appears**





Possible cause	Solution
<ul style="list-style-type: none"> Various situations can lead to an error message. 	<ul style="list-style-type: none"> ➤ Cancel the error message by pressing the  button. ➤ Disconnect the power supply for about 1 minute. ➤ Reconnect the power supply. ➤ If the error message appears again, note down the error message in full (message, serial number (FN) and error number (E)). ➤ Disconnect the power supply. ➤ Call Customer Services.

... **UX / EXX see instructions**
FN XXX XXXXXX **appears**

Possible cause	Solution
<ul style="list-style-type: none"> • Interruption in the power supply. 	<ul style="list-style-type: none"> ▶ Cancel the error message by pressing the  button. ▶ Disconnect the power supply for about 1 minute. ▶ Reconnect the power supply. ▶ If the error message appears again, note down the error message in full (message, serial number (FN) and error number (E)). ▶ Disconnect the power supply. ▶ Call Customer Services.

17.2 After a power failure

After a power failure,  flashes in the right digital display and the  symbol flashes. «Power failure»  «Set time» appears in the plain text display.

- ▶ Turn the  adjusting knob to set the hour.
- ▶ Press the  adjusting knob to confirm.
- ▶ Turn the  adjusting knob to set the minutes.
- ▶ Press the  adjusting knob again to confirm the time.



The user settings remain unchanged.





If a power failure occurs during «Soft roasting»/«BakeOmatic»/«GourmetSteaming»/«Recipes»/«Own recipes»/«Keep warm» or «Hygiene», these programmes will be aborted. It will not be possible to resume these programmes.

If a power failure occurs during descaling, it will continue automatically after the time has been reset.

18 Accessories and spare parts

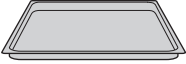
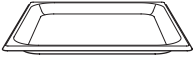
Please give model number and exact description when ordering parts.

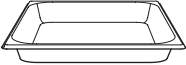
Accessories

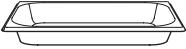
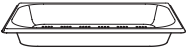
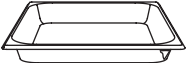
		Width × Depth × Length [mm]
Original baking tray * with TopClean		380 × 29 × 452
Stainless steel tray *		380 × 25 × 452
Cooking tray, perforated, stainless steel *		380 × 25 × 452
Wire shelf *		380 × 26 × 452
Cooking tray, unperforated, stainless steel, 2/3 GN		325 × 40 × 354
Stainless steel tray, 1/3 GN		325 × 20 × 177
Cooking tray, unperforated, stainless steel, 1/3 GN		325 × 40 × 177
Cooking tray, perforated, stainless steel, 1/3 GN		325 × 40 × 177
Cooking tray, unperforated, with lip, stainless steel, 2/3 GN		325 × 40 × 354

* Included in scope of delivery.

Width × Depth × Length
[mm]

Roller runner

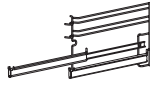

Round TopClean baking tray
ø 24 cm/ø 29 cm/ø 31 cm



U-shape terrine mould with lid

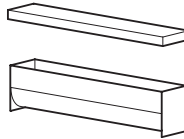

60 × 60 × 300

V-shape terrine mould with lid

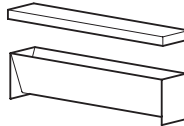

55 × 55 × 300

Porcelain dish, 1/3 GN

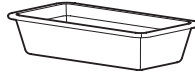

325 × 60 × 177

Porcelain dish, 1/2 GN



325 × 60 × 265

Porcelain dish, 2/3 GN

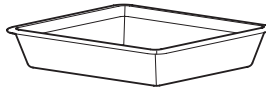

325 × 60 × 354

Stainless steel steam insert

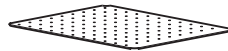

257 × 5 × 109

252 × 5 × 197

290 × 5 × 254



The dimensions correspond to Gastronorm 1/3 GN, 1/2 GN or 2/3 GN.

Recipe book *

Tips on settings *

* Included in scope of delivery.

Spare parts

Shelf guide,
left/right

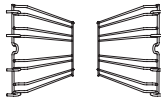

Knurled nut



Lid for water tank



Water tank

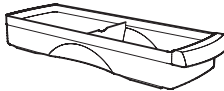

Food probe with straight
handle



19 Technical data

External dimensions

- See Installation Instructions

Electrical connection

- See identification plate 1.

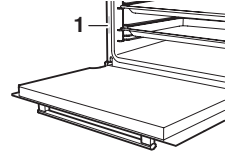

Note for testing institutes

The energy efficiency class according to EN 50304/EN 60350 is determined using the  operating mode. Placing thermocouples between the appliance door and the seal can cause leaks and hence erroneous measurements. The usable volume within the meaning of EN 50304/EN 60350 is obtained with the shelf guides disassembled.

General note

Maximum load capacity: 3 kg

Measurement of the temperature in the cooking space

The temperature of the cooking space is measured when the cooking space is empty according to an internationally accepted standard. Own measurements may be inaccurate and are not suitable for checking the accuracy of the temperature.

Automatic energy-saving stand-by

To avoid consuming power unnecessarily, the appliance is equipped with automatic energy-saving stand-by.



To reduce power consumption to an absolute minimum, select «Time display» «invisible» in the user settings. Despite automatic energy-saving stand-by, all safety functions are active.

20 Disposal

Packaging

- All packaging materials (cardboard, plastic film (PE) and polystyrene (EPS)) are marked and should, if possible, be collected for recycling and disposed of in an environmentally friendly way.

Disconnection

- Disconnect the appliance from the mains. With a fixed appliance, this is to be carried out by a qualified electrician!

Safety

- Disable the appliance to prevent accidents caused by improper use, especially through children playing.
- Pull the plug out of the mains socket or have the appliance disconnected from the mains by a qualified electrician. Then cut off the mains cable.

Disposal

- The old appliance should not be discarded as worthless rubbish. If disposed of correctly, the raw materials can be recovered for recycling.
- The  symbol on the identification plate warns that the appliance may not be disposed of in normal household waste.
- The appliance must be disposed of in accordance with local regulations on waste disposal. For more information on the handling, disposal and recycling of the product, please contact the local authorities, the local recycling facilities for household waste or the retailer from whom you purchased the appliance.

21 Notes

22 Index

- A**
- Accessories 14, 81
 - Cleaning 75
 - Acoustic signal 27, 29
 - Adjusting knob 19
 - Appliance
 - Switching off 25
 - Appliance description 11
 - Appliance door 13
 - Removing 74
- B**
- BakeOmatic 50
 - Starting 52
 - Baking tray, round. 17
 - Before using for the first time 6
 - Browning
 - Uneven 67
 - Browning, degree of 50
 - Buttons 12
- C**
- Care 73
 - Checking and making temporary
 - Changes 56
 - Childproof lock 27, 28
 - Cleaning 73
 - Climate sensor 13
 - Cloths
 - Warm, moist 65
 - Construction 11
 - Contrast 27, 30
 - Cooking space
 - Cleaning 76
 - Temperature measurement. 84
 - Temperature sensor 13
 - Ventilation 13
 - Cooking space temperature
 - Checking/Changing 24
 - Selecting. 24
 - Cooking trays 15, 18
- D**
- Delayed start. 37
 - Descaler
 - Descaling 71
 - Operating time remaining 69
 - Descaler 70
 - Descaling 69
 - Disconnection. 86
 - Display elements. 12
 - Displays 12
 - Disposal 86
 - Door seal 13
 - Replacing 75
- E**
- Electrical connection. 84
 - Energy
 - Saving. 68
 - Exterior
 - Cleaning 73
 - External dimensions 84
- F**
- F/E messages. 79
 - Factory settings. 27, 31
 - Flap control. 27, 31
 - Food probe. 16, 44
 - Positioning 44
 - Food probe temperature. 45
- G**
- GourmetSteam 54
 - Starting 55
- H**
- Hot air 42, 65
 - Hot air + steaming 42, 66
 - Hot air fan. 13
 - Hot air humid 42
 - Hygiene. 68

-
- I**
Identification plate 84
Illumination 13, 27, 29
- K**
Keeping food warm 63
Knurled nut 13
- L**
Language. 27, 28
 Resetting 28
Levels 13
Light bulb, replacing 76
Load capacity 84
- M**
Maintenance 73
Model no. 2
- O**
Operating elements 12
Operating modes. 40
 Changing 23
 Selecting 23
Operating the appliance 19
Operating time. 35
Original baking tray with TopClean 14
Own recipes
 Clearing 62
 Copying 62
 Creating 60
 Making recipe settings 60
- P**
Packaging 86
Plain text display 19
Porcelain dishes 17
Power failure 80
Preheating 68
Professional baking 40, 66
- Q**
Quick instructions 92
- R**
Recipes 57
 Changing. 59
 Creating own. 60
 Starting 58
Refilling water tank 22
Regenerating 40, 65
Removing cooked food 24
Repair service 91
Roller runner 18
- S**
Safety 86
Safety precautions
 Before using for first time 6
 Children in the home. 8
 Correct use 7
 Note on use. 8
Saving energy 68
Shelf guides. 75
Socket for food probe 13
Soft roasting 47
 Changing food probe
 temperature. 49
 Changing operating time. 49
 Positioning the food probe 47
 Preparing the meat 47
 Selecting and starting 48
Spare parts 81, 83
Stainless steel tray. 14
Stand-by 85
Steam
 Activating/Deactivating 66
Steam inlet 13
Steam insert 17
Steaming. 40, 64
Switching off 25, 36, 39
Switching off before
 time 49, 53, 56, 59
Switch-off time 37
 Setting. 38
Symbols. 2, 12

T

Technical data	84
Temperature unit	27, 30
Terrine moulds	17
Time display	27, 29
Time format	27, 30
Time functions	32
Time, setting	32
Timer	33
Tips and tricks	64
Trouble-shooting	77
Type	2

U

U/E messages	80
Use	
Example	21
User settings	26
Using for the first time	21

V

Validity	2
--------------------	---

W

Water hardness	27, 30
Water tank	16
Emptying	25
Filling	22
Refilling	22
Wire shelf	15

23 Repair service



The TROUBLE-SHOOTING section will help you to carry out small repairs yourself, saving you the time and trouble of calling out a service technician and the cost that goes along with it.

Whether you contact us about a malfunction or an order, please always state the serial number (FN) and the model type of your appliance. Enter these details below and also on the service sticker which comes with the appliance. Stick it in a conspicuous place or in your telephone or address book.

FN

Appliance





You will also find the same details on the certificate of guarantee, the original sales invoice and the identification plate of the appliance.

- ▶ Open the appliance door.
 - The identification plate is on the left-side panel.



Quick instructions

Please first read the safety precautions in the operating instructions!

To set the time

- Press the  button.
- Turn the  adjusting knob to set the hour.
- Press the  button again.
- Turn the  adjusting knob to set the minutes.

To select the operating mode

- Press the  button repeatedly until the desired operating mode appears.
- Turn the  adjusting knob to set the cooking space temperature.

To switch off the appliance

- Press the  button.

To set the timer

- Press the  button.
- Turn the  adjusting knob to set the timer duration.

V-ZUG Ltd

Industriestrasse 66, CH-6301 Zug

vzug@vzug.ch, www.vzug.com



J864.352-2