

Operating instructions

DWPQG/DIPQG

Range hood

Thank you for choosing to buy one of our products. Your appliance is made to high standards and is easy to use. Nevertheless, please take the time to read these operating instructions in order to familiarize yourself with the appliance and get the best use out of it.

Please follow the safety precautions.

Modifications

Text, diagrams and data correspond to the technical standard of the appliance at the time these operating instructions went to press. The right to make technical modifications for the purpose of the further development of the appliance is reserved.

Validity

The product family (model number) corresponds to the first alphanumeric on the identification plate. These operating instructions apply to:

Type	Product family	Size system	Motor housing no.
DWPQG9	62004	90	H4.2604 (K630003)
DWPQG12	62005	120	H4.2605 (K630004)
DIPQG10	63004	100	H4.2608 (K630002)
DIPQG12	63005	120	H4.2774

Variations depending on the model are noted in the text.

Contents

1 Safety precautions	4
1.1 Symbols used.....	4
1.2 General safety precautions.....	5
1.3 Before using for the first time.....	6
1.4 Correct use.....	6
1.5 Children in the home	6
1.6 Note on use.....	7
2 Disposal	9
3 Your appliance	10
3.1 Appliance description.....	10
3.2 Extraction model.....	10
3.3 Recirculation model.....	10
3.4 Equipment.....	10
3.5 Construction	11
3.6 Operating and display elements	12
4 Operating the appliance	13
4.1 Using for the first time	13
4.2 Operation	15
4.3 After-running time.....	15
4.4 Intensive level.....	16
4.5 Illumination	16
4.6 Saturation indicator	17
4.7 Wipe protection	17
4.8 Operation with remote control	17
5 Care and maintenance	18
5.1 Cleaning the housing	18
5.2 Cleaning the grease filters and combi filters	19
5.3 Replacing the activated charcoal filters.....	21
5.4 Replacing the LEDs.....	23
6 Trouble-shooting	24
6.1 What to do if	24
7 Accessories and spare parts	25
8 Technical data	26
9 Index	27
11 Service & Support	31

1 Safety precautions

1.1 Symbols used



Denotes important safety precautions.

Failure to observe said precautions can result in injury or in damage to the appliance or fittings!



Information and precautions that should be observed.



Information on disposal



Information about the operating instructions

► Indicates step-by-step instructions.

– Describes how the appliance reacts to the steps taken.

• Indicates a list.

1.2 General safety precautions



- Read the operating instructions before using the appliance for the first time!



- This appliance can be used by children aged 8 and above and by persons with reduced physical, sensory or mental capabilities, or lack of experience and/or knowledge, provided they are supervised or have been instructed on the safe use of the appliance and have understood the hazards involved. Children shall not play with the appliance. Cleaning and user maintenance shall not be undertaken by children without supervision.
- If an appliance is not equipped with a mains cable and a plug or other means for disconnecting from the mains with a contact opening on each pole complying with the conditions of overvoltage category III for full isolation, an isolating device must be incorporated into the permanently installed electrical installation in accordance with the installation regulations.
- If the mains cable of this appliance is damaged, it must be replaced by the manufacturer or its Customer Services or a similarly qualified person in order to avoid hazard.

1.3 Before using for the first time

- The appliance must be installed and connected to the electricity supply in accordance with the separate installation instructions. Have a qualified fitter/ electrician carry out the necessary work.
- Dispose of the packaging material in accordance with local regulations.

1.4 Correct use

- The appliance is designed for use in the home for extracting cooking odours from above a cooking area.
- Any repairs, modifications or manipulations to the appliance, especially any electrically live parts, may only be carried out by the manufacturer, its Customer Services or a similarly qualified person. Repairs if carried out incorrectly could cause serious injury or damage to the appliance and fittings as well as affect the functioning of the appliance. If the appliance is not working properly or in case of a repair order, follow the instructions given in the 'Repair service' section. If necessary, please contact our Customer Services.
- Use original spare parts only.
- Retain these operating instructions for future reference. If you sell the appliance or pass it on to a third party, please ensure these operating instructions accompany the appliance, together with the instructions on installation. In this way, the new owner can inform themselves about how to use the appliance correctly and read the pertinent safety precautions.

1.5 Children in the home

- Packaging material, e.g. plastic film and polystyrene, can be dangerous for children. Danger of suffocation! Keep packaging material away from children.
- The appliance is designed for use by adults who are familiar with these operating instructions. Children are often unable to recognize the danger of electrical appliances. Ensure proper supervision and do not allow children to play with the appliance – there is a danger that children could hurt themselves.

1.6 Note on use

- If the appliance is visibly damaged, do not use it. Contact Customer Services.
- If the appliance is not operating properly, disconnect it from the power supply immediately.
- If the mains cable of the appliance is damaged, it must be replaced by Customer Services in order to avoid hazard.
- Caution: Accessible parts may become hot when used with cooking appliances.
- Do not flambé food underneath the appliance. Grease filters if laden with grease could catch fire.
- If frying on the cooking surface, do not leave the frying appliance unattended. The cooking oil in the frying appliance could overheat and catch fire. Constantly monitor the temperature of the cooking oil, keeping it below the temperature at which it can catch fire. Change the cooking oil regularly – dirty oil catches fire more easily than clean oil.
- Observe the cleaning intervals. Failure to do so can increase the fire hazard due to the excessive build-up of grease in the grease filters.
- Do not operate the individual cooking zones of the cooking surface without a pan on them or with an empty pan on them so as to avoid damaging the appliance or the kitchen fittings through a build-up of heat. Avoid open fires with oil, gas, wood and coal fired cookers.
- Ensure there is adequate ventilation when the extraction fan is on so as to avoid creating a disturbing underpressure in the kitchen and to achieve optimal air extraction.
- Avoid a cross-current of air, which could blow the cooking vapours across the cooking area.
- If other appliances – fuelled by gas or other fuels – are being used at the same time, ensure that there is a sufficient supply of fresh air. This does not apply to air recirculation appliances.
- If other firing systems are being used at the same time (e.g. wood, gas, oil or coal-fired heating appliances), safe operation is only possible providing a room negative pressure of 4 Pa (0.04mbar) is not exceeded at the location of the appliance. Risk of toxic fumes! An adequate flow of fresh air must be guaranteed e.g. via non-closable openings in doors or windows and in combination with an air-intake/exhaust-air wall box or by other technical means.

1 Safety precautions

- When carrying out maintenance work on the appliance, including replacing the light bulb, cut off the electricity supply to the appliance (remove the screw fuse from the holder or switch the circuit breaker off, or disconnect from the mains supply).
- When cleaning the appliance make sure no water gets inside the appliance. Use a moderately damp cloth. Do not spray the inside or outside of the appliance with water. Do not use a steam cleaner. If water gets inside the appliance, it can cause damage.

2 Disposal

Packaging

- All packaging materials (cardboard, plastic film (PE) and polystyrene (EPS)) are marked and should, if possible, be collected for recycling and disposed of in an environmentally friendly way.

Disconnection

- Disconnect the appliance from the mains. With a fixed appliance, this is to be carried out by a qualified electrician!

Safety

- Disable the appliance to prevent accidents caused by improper use, especially through children playing.
- Pull the plug out of the mains socket or have the appliance disconnected from the mains by an electrician. Then cut the mains cable off flush with the appliance.
- Remove or disable the lock on the appliance door.

Disposal

- The old appliance should not be discarded as worthless rubbish. If disposed of correctly, the raw materials can be recovered for recycling.



- The  symbol on the identification plate warns that the appliance may not be disposed of in normal household waste.
- The appliance must be disposed of in accordance with local regulations on waste disposal. For more information on the handling, disposal and recycling of the product, please contact the local authorities, the local recycling facilities for household waste or the retailer from whom you purchased the appliance.

3 Your appliance

3.1 Appliance description

The appliance is designed for use in the home for extracting cooking odours from above the cooking area. This particular model can be used as a wall or island hood to extract or recirculate air.

3.2 Extraction model

The integrated fan extracts cooking fumes and smells from above the cooking surface. The metal grease filters clean the air, which is ducted outside.



When in use, ensure there is a sufficient supply of fresh air. Exhaust air requires intake air.

The saturation indicator for the activated charcoal filter must be deactivated. (see page 13)

3.3 Recirculation model

The cooking fumes and smells above the cooking area are filtered through the metal grease filters and then passed through an activated charcoal filter. The filtered air is then circulated back into the room.

3.4 Equipment

- 1 extractor fan with 4 power levels:
 - 1 = low, 2 = medium, 3 = high, and intensive level.
 - Power levels 1–3 are suitable for continuous operation.
 - The intensive level is used for short bursts of intensive extraction of cooking fumes and smells, e.g. when searing meat. The intensive level runs for 5 minutes.
- Illumination
- 2 or 3 grease filters (depending on hood size)
- 4 or 5 combi filters (depending on hood size)
- 2 activated charcoal filters **A**
- 1 or 3 activated charcoal filters **B** (depending on range hood model)

3.5 Construction

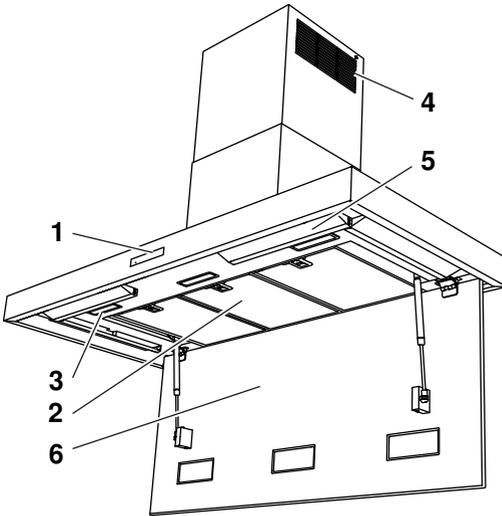

- 1 Operating and display elements
- 2 Grease filter
- 3 Illumination
- 4 Return air in recirculation model
- 5 Combi grease filter
- 6 Glass cover (fold-down)



If your appliance has lateral ventilation slits (see no. 4 in the figure) then it is a recirculation model.

3.6 Operating and display elements



Buttons

	ON/OFF button		Illumination ON/OFF
	Power level selection		Timer

Displays

	Power level 1	
	Power level 2	
	Power level 3	
	• Flashing:	Intensive level
	Wipe protection	
	• Illuminated:	Wipe protection activated
	Timer	
	• Illuminated:	Timer activated
	Saturation indicator for grease filters	
	• Flashing:	Clean grease filters
	Saturation indicator for activated charcoal filters	
	• Flashing:	Replace activated charcoal filters



Depending on the model and features, the specification of the appliance may partly differ in individual details from the standard specification described herein.

4 Operating the appliance

4.1 Using for the first time

Configuring the appliance

The appliance can be used in the extraction or recirculation mode. The appliance is set up as a recirculation hood with 5 kg of activated charcoal ex-factory. With this setting, the service life of the activated charcoal filter is 1,200 operating hours. The operating hours counter must be configured for the version of the range hood with 2.5 kg of activated charcoal. The saturation indicator can also be adjusted to your cooking habits.



If the appliance is to be used as an extraction model, the saturation indicator for the activated charcoal filter must be deactivated.

Amount of activated charcoal used

- ▶ Remove the grease filters (see Cleaning the grease filters).
 - For the length of the motor housing, see on the inside (see arrow).

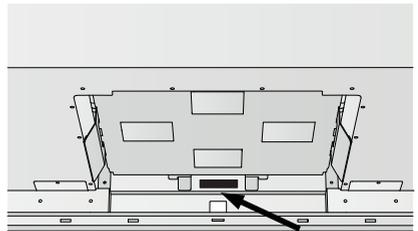

Short motor housing = 2.5 kg activated charcoal

Long motor housing = 5 kg activated charcoal

Activating and changing the saturation indicator for the activated charcoal filter

- ▶ Switch the appliance off.
- ▶ Depress the  button for 3 seconds.
 - The  and  displays flash.
- ▶ Press the  button repeatedly until the desired setting illuminates in the display.
 - The setting selected will be automatically accepted after 5 seconds.

The range hood is now set up as a recirculation model.

Settings options for the saturation indicator

Amount of activated charcoal	Cooking intensity	Operating hours	Power level display
5 kg	Standard, for not overly frequent and/or pungent cooking	1200 h	
5 kg	For more frequent and/or more pungent cooking	700 h	
2.5 kg	Standard, for not overly frequent and/or pungent cooking	700 h	
2.5 kg	For more frequent and/or more pungent cooking	400 h	

If the appliance is to be used as an extraction model, the hours counter for the activated charcoal filters must be deactivated.

Deactivating the saturation indicator for the activated charcoal filters

- ▶ Switch the appliance off.
- ▶ Depress the  button for 3 seconds.
 - The  and  displays flash.
- ▶ Depress the  button again for 3 seconds.
 - The  and  displays go out.

The range hood is now set up as an extraction model.

4.2 Operation

Switching the appliance on

- ▶ Pressing the  button switches the appliance on at power level 1.
- ▶ Press the  button repeatedly until the desired power level is reached.
 - The power level currently being used illuminates in the corresponding display.
 - The  display flashes when the intensive level is selected.



We recommend switching the appliance on at power level 1 some 5 minutes before cooking. Use a low power level for normal cooking smells and a higher power level for very strong cooking fumes and smells.

Switching the appliance off

- ▶ Press the  button.



After you have finished cooking, allow the appliance to run for another 15 minutes so that the cooking fumes and smells can be extracted.

4.3 After-running time

- ▶ Switch the appliance on.
- ▶ Press the  button to select the desired power level.
- ▶ Press the  button to activate the after-running time function.

With the after-running time function, the appliance keeps running according to the following table and then switches off automatically.

Button	After-running time
	20 minutes
	15 minutes
	10 minutes
 Flashing	5 minutes

4.4 Intensive level

The intensive level can be selected when the appliance is switched on.

▶ Depress the  button for 2 seconds.

– The  display flashes.

After 5 minutes, the appliance switches back to the previously selected power level.

▶ Press the  button to stop the intensive level before the 5 minutes has elapsed.

– The appliance switches back to the previously selected power level.

4.5 Illumination

▶ Press the  button to switch the illumination on.

▶ Press the  button again to switch the illumination off.

4.6 Saturation indicator

Saturation indicator for the grease filters

The  display flashes after 20 operating hours. The saturation level has been reached and the grease filters and combi filters must be cleaned.

Saturation indicator for the activated charcoal filters

The  display illuminates after 1,200, 700 or 400 operating hours, depending on the setting selected. The saturation level has been reached and the activated charcoal filters must be replaced.

4.7 Wipe protection

This function prevents the range hood from being switched on accidentally while cleaning.

The range hood must be switched off.

- ▶ Depress the  button for 5 seconds.
 -  illuminates in the display.
 - The wipe protection switches off automatically after 30 seconds and the display goes out.

4.8 Operation with remote control

In order to be able to operate the range hood by using the optional remote control, you need to have activated the hood for remote control.

- ▶ With the range hood switched on, ensure that the illumination is switched off.
- ▶ With the range hood switched off, hold the  button depressed for 5 seconds until the  display flashes.
- ▶ When the  display flashes, press any button on the remote control.

The range hood is now synchronized with the remote control.

5 Care and maintenance

5.1 Cleaning the housing



Take care that no water gets into the housing! If water gets into the housing, it can cause damage.

Do not use abrasive cleaners, scouring pads, steel wool etc. to clean the appliance as they can damage the surface.

Remove the screw fuse or switch off the circuit breaker.

Cleaning the outside/inside

- ▶ Clean the outside using a slightly damp cloth – and detergent if necessary – and wipe dry.

Grease and condensate water can build up around the grease filters on the inside.

- ▶ Clean using a slightly damp cloth – and detergent if necessary – and wipe dry.

5.2 Cleaning the grease filters and combi filters

The grease filters and combi filters must be cleaned at least once a month with normal use or whenever the  button flashes. If cleaned monthly, the service life of the grease filters is as long as that of the range hood.

Removing the grease filters and combi filters

- ▶ Hold the glass cover **1** at the front and carefully swing down.
- ▶ Holding the combi filter **2** firmly, carefully pull down and out of the magnetic fixture.
- ▶ Pull the grip **4** on the grease filter **3** down.
- ▶ Carefully pull the grease filter **3** down and out of the fixture.

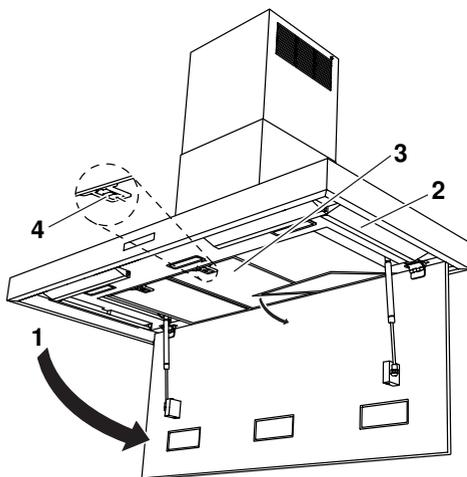

Do not damage the grease filters.

Cleaning

- ▶ Clean the grease filters and combi filters on their own in an upright position in a dishwasher.
- ▶ Set the dishwasher to an «intensive» or «heavy» soiling programme.



Cleaning may cause the grease filters to become discoloured. This will not affect the functioning of the filters in any way.

If no dishwasher is available:

- ▶ Clean the grease filters in the sink with hot water and detergent.
- ▶ Then soak the filters in hot water in the sink for about 2 hours and finally clean with a washing-up brush.



Do not damage the metal mesh of the combi filter.

Installing the grease filters and combi filters

- ▶ Insert the grease filters **3** into the slots at the back.
- ▶ Pull the grip **4** down.
- ▶ Swing the grease filters **3** up and engage in position.
- ▶ Insert the raised part of the combi filters **2** into the white recessed parts of the hood. Ensure that the metal mesh is aligned in the direction of the edge of the glass cover.
- ▶ Carefully swing up the glass cover **1** until all the magnets are engaged.
- ▶ With the appliance switched off, depress the  button for 5 seconds to reset the saturation indicator.
- ▶ The flashing display goes out.

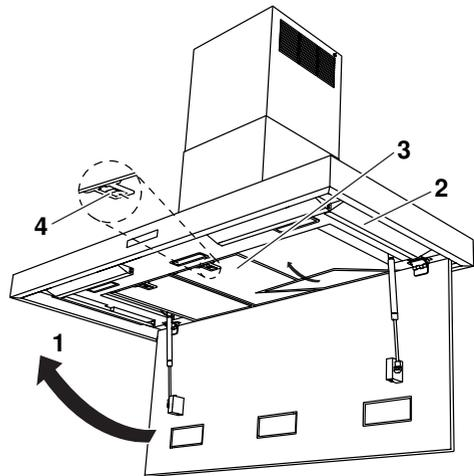

5.3 Replacing the activated charcoal filters



Activated charcoal filters cannot be washed or regenerated.

Activated charcoal filters are only used in in the recirculation model. An activated charcoal filter becomes less effective with use. A range hood can contain 5 kg or 2.5 kg of activated charcoal, depending on the appliance model. With normal use, the activated charcoal filters have to be replaced at least every 5 years (for 5 kg) or 3 years (for 2.5 kg) or whenever the  button illuminates.



Spent activated charcoal filters can be disposed of in the household waste.

The activated charcoal filters have been developed especially for this appliance and can only be ordered from V-ZUG Ltd's Customer Services.

The activated charcoal filter consists of:

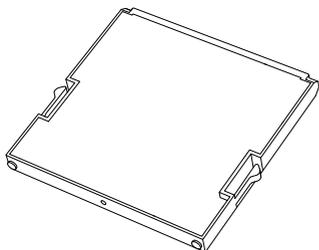

Activated charcoal filter **A**

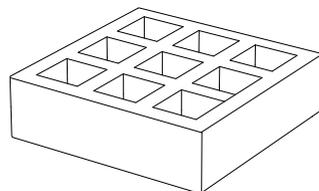

Activated charcoal filter **B**

Removing the activated charcoal filters

- ▶ Disconnect the hood from the mains power supply.
- ▶ Cover over the hob to protect it from getting damaged.
- ▶ Remove and clean the grease filters. Cleaning the grease filters and combi filters (see page 19)
- ▶ Press the metal cover **C** upwards and at the same time press both filter holders outwards.

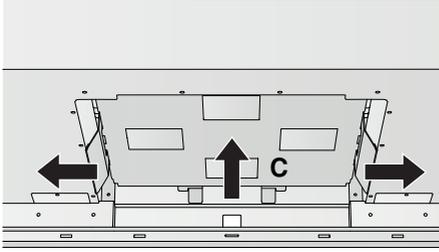

- ▶ Remove the metal cover **C** from below and clean it.
- ▶ Press both filter holders outwards again and remove activated charcoal filters **B** one by one from below.

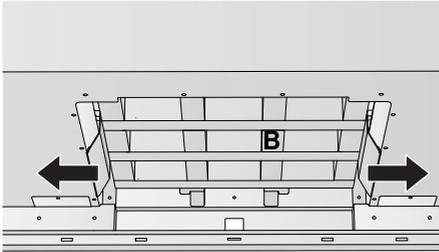

- ▶ Remove activated charcoal filter **A** by pulling it downwards.

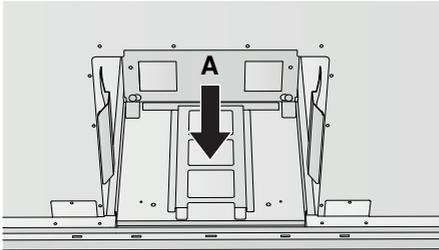

- ▶ Loosen the activated charcoal filter **A** from the metal holder **E**.

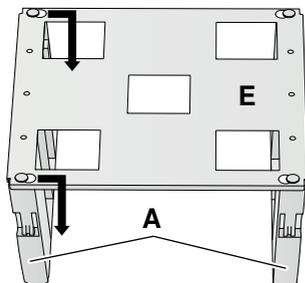

- ▶ Clean the metal holder in a dishwasher or by hand.

Inserting the activated charcoal filters

- ▶ Fit activated charcoal filters **A** to the metal holder **E**.
- ▶ Push activated charcoal filters **A** straight upwards until they engage.
 - Activated charcoal filters **A** are located in the side panels.
- ▶ One by one, push activated charcoal filters **B** upwards until they engage.
- ▶ Push metal cover upwards until it engages.
- ▶ Put back the grease filters.
- ▶ Connect the appliance to the mains power supply.
- ▶ With the appliance switched off, depress the  button for 5 seconds to reset the saturation indicator.
 - The flashing display goes out.

5.4 Replacing the LEDs

For safety reasons, the LEDs must be replaced by our Customer Services.

6 Troubleshooting

6.1 What to do if ...

... the illumination is not working

Possible cause	Solution
<ul style="list-style-type: none">• Fuse or automatic circuit breaker for electrical installations in the home is defective.	<ul style="list-style-type: none">▶ Replace the fuse.▶ Reset the automatic circuit breaker.
<ul style="list-style-type: none">• An interruption in the power supply.	<ul style="list-style-type: none">▶ Check the power supply.
<ul style="list-style-type: none">• LED is defective.	<ul style="list-style-type: none">▶ Inform Customer Services.

... the appliance is not extracting enough air

Possible cause	Solution
<ul style="list-style-type: none">• The grease filters are dirty.	<ul style="list-style-type: none">▶ Clean the grease filters.
<ul style="list-style-type: none">• Only for recirculation model: The activated charcoal filters are saturated.	<ul style="list-style-type: none">▶ Replace the activated charcoal filters.
<ul style="list-style-type: none">• Only for extraction model: The fresh air intake is insufficient.	<ul style="list-style-type: none">▶ Ensure the fresh air intake is sufficient.

7 Accessories and spare parts

Please give product family of the appliance and exact designation of the accessory or spare part when ordering parts.*

Grease filter

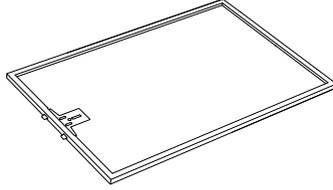

Combi filter

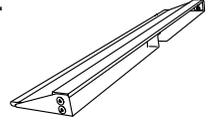

Activated charcoal filter

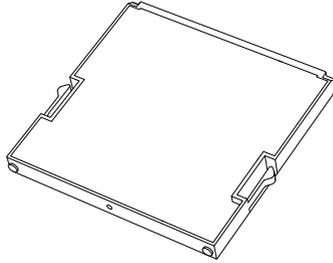

+

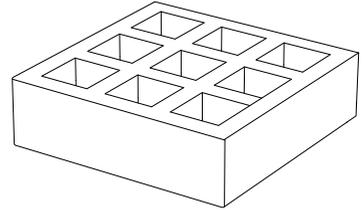

* When ordering the activated charcoal filter give the length of the motor housing (see page 13).

8 Technical data

Electrical connection

- ▶ See identification plate.
- ▶ Remove the grease filters.
 - The identification plate is located on the inside of the appliance.

9 Index

A

Accessories	25
Activated charcoal.....	13
Activated charcoal filter.....	10
Replacing	21
Saturation indicator	13, 14, 17
After-running time	15
Amount of activated charcoal used	13
Appliance description.....	10

C

Care	18
Children in the home.....	6
Cleaning	
Grease filter.....	19
Housing.....	18
Configuring the appliance.....	13
Construction	11

D

Disconnection	9
Display elements	12
Disposal	9

E

Electrical connection.....	26
Equipment.....	10
Extended warranty.....	31
Extraction model.....	10

G

Grease filter	
Cleaning.....	19
Installing.....	20
Saturation indicator.....	17

I

Identification plate	26
Illumination	16
Intensive level.....	16

L

LED	
Replacing	23

M

Model number	2
--------------------	---

N

Notes.....	29
------------	----

O

Operating elements.....	12
Operating the appliance.....	13
Operation with remote control	17

P

Packaging.....	9
Product family.....	2

Q

Quick instructions.....	32
-------------------------	----

R

Recirculation model	10
Removing	
Combi filter	19
Grease filter.....	19

S

Safety.....	9
Safety precautions	
Before using for the first time	6
Children in the home	6
Correct use.....	6
General.....	5
Note on use.....	7
Saturation indicator	17
Activated charcoal filter	13, 14, 17
Grease filter.....	17
Settings options.....	14
Service & Support	31
Spare parts	25

Switching off.....	15
Switching on.....	15
Symbols.....	4

T

Technical data.....	26
Technical enquiries.....	31
Trouble-shooting.....	24
Type.....	2

V

Validity.....	2
---------------	---

W

What to do if	
The appliance is not extracting	
enough air.....	24
What to do if ...	
Illumination not working.....	24
Wipe protection.....	17

10 Notes

11 Service & Support



The «Troubleshooting» chapter provides valuable information for dealing with minor operating faults. This saves you the time, effort and potential cost of having to call out a service technician.

Information on the V-ZUG warranty can be found at www.vzug.com →Service →Warranty information. Please read this information carefully.

Please register your V-ZUG appliance online immediately at www.vzug.com→Service→Warranty registration. This will allow you to take advantage of the best possible support in the event of an fault in the appliance during the warranty period. You will require the serial number (FN) and appliance designation to complete the registration process. This information can be found on the identification plate for your appliance.

My appliance information:

FN: _____ **Appliance:** _____

Always have this appliance information to hand when you contact V-ZUG. Thank you.

► Remove the metal grease filter.

– The identification plate is located on the inside of the appliance.

Requesting repairs

You can find the telephone number for your nearest V-ZUG service centre at www.vzug.com→Service→Service hotline.

Technical enquiries, accessories, extended warranty

V-ZUG is happy to help with your general administrative and technical enquiries, orders for accessories and spare parts, or information relating to advanced service agreements.

Please first read the safety precautions in the operating instructions!



Buttons

	ON/OFF button		Illumination ON/OFF
	Power level selection		Timer

Displays

	Power level 1	
	Power level 2	
	Power level 3	
	• Flashing:	Intensive level
	Wipe protection	
	• Illuminated:	Wipe protection activated
	Timer	
	• Illuminated:	Timer activated
	Saturation indicator for grease filters	
	• Flashing:	Clean grease filters
	Saturation indicator for activated charcoal filters	
	• Flashing:	Replace activated charcoal filters



1007039-R01

V-ZUG Ltd

Industriestrasse 66, P.O. Box 59, CH-6301 Zug

info@vzug.com, www.vzug.com

