



! The appliance should be installed by qualified personnel only. Each step must be carried out and checked in full in the order specified.

Validity

These installation instructions are valid for the following models:

Product family	With normal mounting frame	Frameless for flush installation	Frameless with bevels	With oversize mounting frame
008, 31013	GK36TISC	GK36TIS.1F	GK36TIS	-
027, 31016	GK46TISC	GK46TIS.1F	GK46TIS	GK46TISU
028, 31017	GK46TIABSC	GK46TIABS.1F	GK46TIABS	GK46TIABSU
88A, 31014	GK46TIMSC	GK46TIMS.1F	GK46TIMS	GK46TIMSU
90A	GK46TIAKSC	GK46TIAKSF	GK46TIAKS	-
95A, 31021	GK46IDC	GK46ID.1F	GK46ID	GK46IDU
96A, 31022	GK46IABDC	GK46IABD.1F	GK46IABD	-
974, 31019	GK46TIASC	GK46TIAS.1F	GK46TIAS	GK46TIASU
31030	GK46TIMASC	GK46TIMASF	GK46TIMAS	-
31037	GK47TIMASC	GK47TIMASF	GK47TIMAS	-
31040	GK47TIMSC/O	GK47TIMSF/O	GK47TIMS	GK47TIMSU
31041	GK37TIMSC	GK37TIMSF	GK37TIMS	-
31059	-	GK47IMADF	-	-
31060	-	GK47IMDF	-	-

General notes

! The directives and standards for low-voltage installations and fire protection must be complied with when installing in flammable material.

Identification plate

The identification plate is located next to the connection plate.

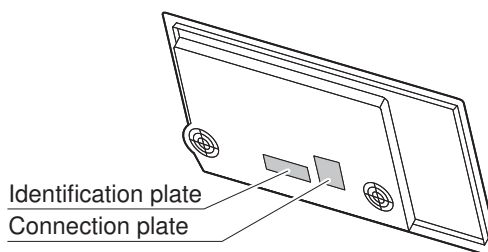

- Affix the second identification plate (supplied) in an accessible position behind the front of the fitted cabinet beneath the appliance.

Installation instructions

Induction hob

GK36 | GK37 | GK46 | GK47



J31037113-R04

28/11/2016

Installation accessories provided

Flush installation:

Designation	Art. no.
Cementing-in instruction	J004133
Sealing tape set	H63283

Oversize mounting frame:

Designation	Art. no.
Adjusting brace set	H61548

Accessories

For all installation variants:

Designation	Art. No.
Ventilation protective plate set for niche width 550 mm	H61082
Ventilation protective plate set for niche width 600 mm	H61083
Ventilation protective plate set for niche width 825 mm	H61084
Ventilation protective plate set for niche width 900 mm	H61085

Flush installation:

Designation	Art. No.
Steel angle set, installation dimension 60	H63772
Steel angle set, installation dimension 80	H63774
Instant adhesive for installing the steel angle Permabond F246 incl. activator, 50 ml tube. From Silitech AG, 3008 Bern.	B11502
Sealant set Complete with cleaning agent, primer type 1105, cartridge with black silicone adhesive, with nozzle. Suitable for all absorbent covering materials (wood and types of natural stone such as marble and granite).	86.3928.85
Special primer type 107 Suitable for non-absorbent covering materials (not suitable for polyethylene, polypropylene or Teflon).	45.2771.76



Electrical connection

! Electrical connections must be carried out by qualified personnel in accordance with the guidelines and standards for low-voltage installations and the specifications of the local electricity supply companies.

A plug-in appliance may only be connected to a socket outlet with earthing contact, installed according to specifications. An all-pole mains isolating device with 3 mm contact opening should be provided in the house wiring system. Switches, plug and socket devices, circuit breakers and fusible cut-outs which are accessible after installation and which have all-poles switching are permissible as isolating devices. Effective earthing and separately installed neutral and earth conductors ensure safe and fault-free operation. After installation, live parts and cables with basic insulation must not be accessible. Check old installations.

- ▶ The appliance is designed for use up to a max. altitude of 2000 m above sea level.
- ▶ Refer to the identification plate for information on the required mains voltage, current type and fuse protection.

The appliance is equipped with a connection cable which must be connected to an on-site junction box.

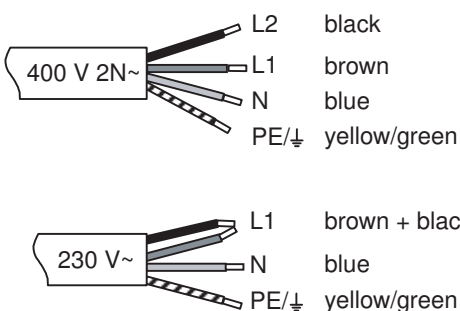
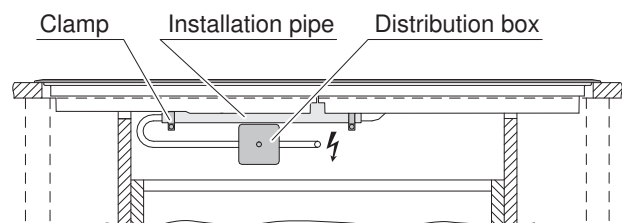

Error message U400

**! Faulty connection:
A pole conductor has been connected to the connection terminal for neutral conductors.**

Quickly disconnect the appliance from the mains!

Ventilation

In order to guarantee good ventilation, a space of ≥ 10 mm height is necessary beneath the appliance.

1. The rear panel of the base unit must be open around the work surface cut-out to guarantee continuous air circulation via the ventilation slits. The air must be drawn in from outside the cabinet and be able to circulate freely from inside the cabinet to the hob.
2. Alternatively, a concealed fresh air supply can ensure air circulation inside the cabinet. In order that enough cold air can be drawn in, there must be a continuous circulation of fresh air that extends outside the cabinet. The air must be drawn in from outside the cabinet and be able to circulate freely from inside the cabinet to the hob.

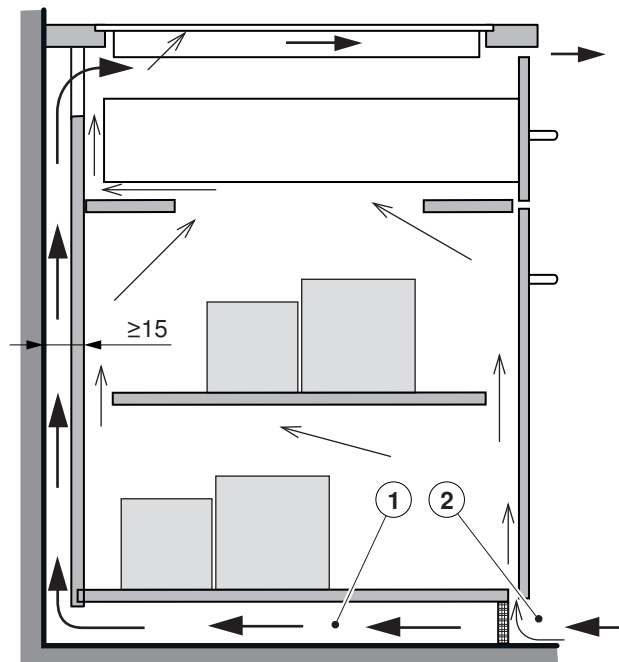

General information about installation

- The work surface must be flat.
Bevels: These guarantee the required level of sealing against liquids.
- To ensure good ventilation, there must be at least 10 mm of space under the appliance.



Normal mounting frame and frameless with bevels

The cooking ring layout of the hob to be fitted can differ from the hob illustrated!

**GK36TIS/C, GK46TIS/C, GK46ID/C,
GK46TIMS/C, GK37TIMS/C, GK47TIMSC/O**

**GK46TIAS/C, GK46TIABS/C, GK46IABD/C,
GK46TIAKS/C, GK46TIMAS/C, GK47TIMAS/C**

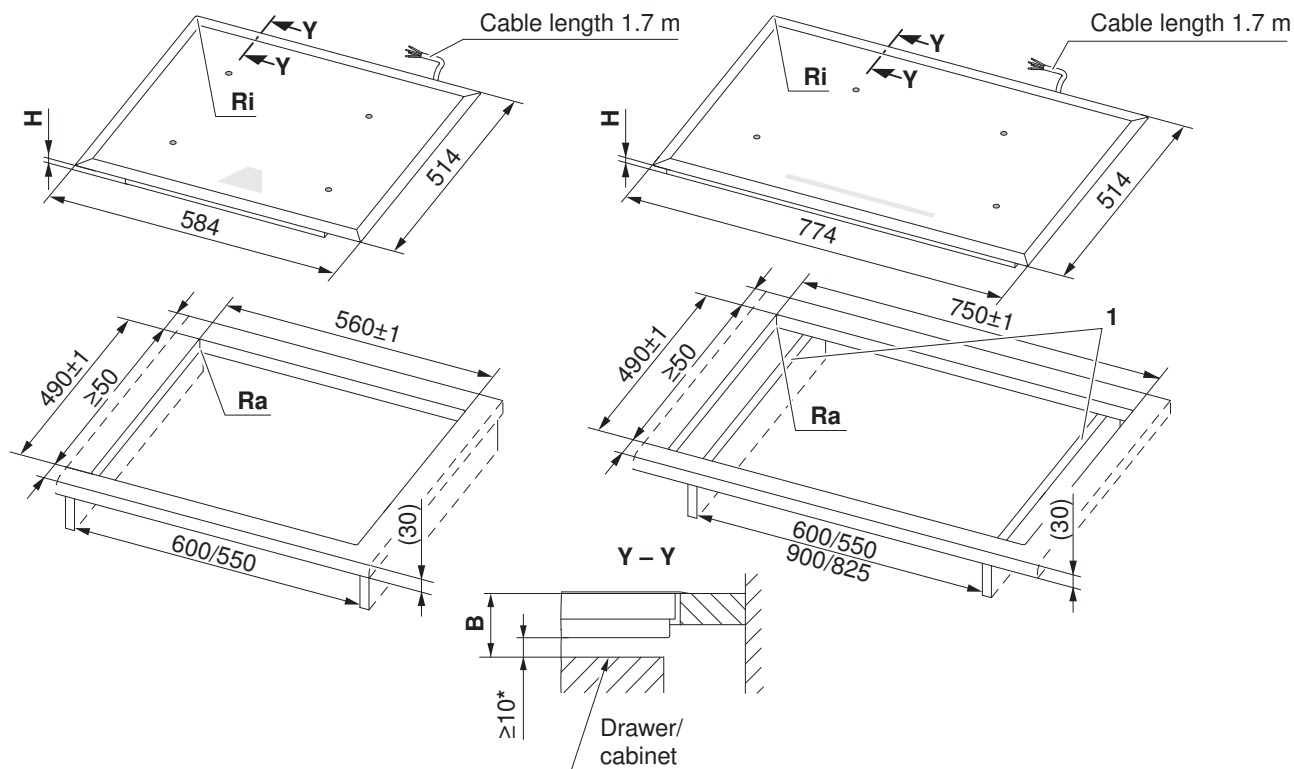

* The clearance space must be maintained!

1 For symmetrical installation, it is not necessary to cut out the side walls.

Type	A – loosely based on manufacturer	B	H	Corner radius Ra/Ri	Remarks
GK36TIS, GK46TIS, GK46ID, GK46TIMS, GK37TIMS	≥30 mm	≥57.7 mm	47.7 mm	10/8 mm	Frameless with bevels
GK46TIAS, GK46TIABS, GK46IABD, GK46TIAKS, GK46TIMAS, GK47TIMAS		≥56.5 mm	46.5 mm		
GK36TISC, GK46TISC, GK46IDC, GK46TIMSC, GK37TIMSC, GK47TIMSC/O		≥59.7 mm	49.7 mm		Normal mounting frame
GK46TIASC, GK46TIABSC, GK46IABDC, GK46TIAKSC, GK46TIMASC, GK47TIMASC		≥58.5 mm	48.5 mm		

A Depth of the work surface (combined with oven installed directly below)

B Required clearance in the service exchange

H Dimension from the top of the work surface to the underside of the hob (fan opening)

Ri Corner radii of the appliances

Ra External corner radii of the cut-out

Installation

1. Create the mounting cut-out accurately.
2. Carefully place the appliance in the mounting cut-out and push against the work surface until flat.



Frameless for flush installation

The cooking ring layout of the hob to be fitted can differ from the hob illustrated.

**GK36TIS.1F, GK46TIS.1F, GK46ID.1F,
GK47IMDF, GK46TIMS.1F, GK47TIMSF/O,
GK37TIMSF**

**GK46TIAS.1F, GK46TIABS.1F, GK46IABD.1F,
GK47IMADF, GK46TIAKSF, GK46TIMASF,
GK47TIMASF**

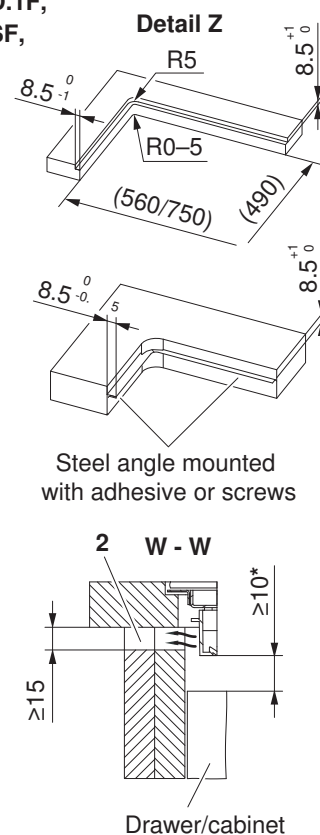
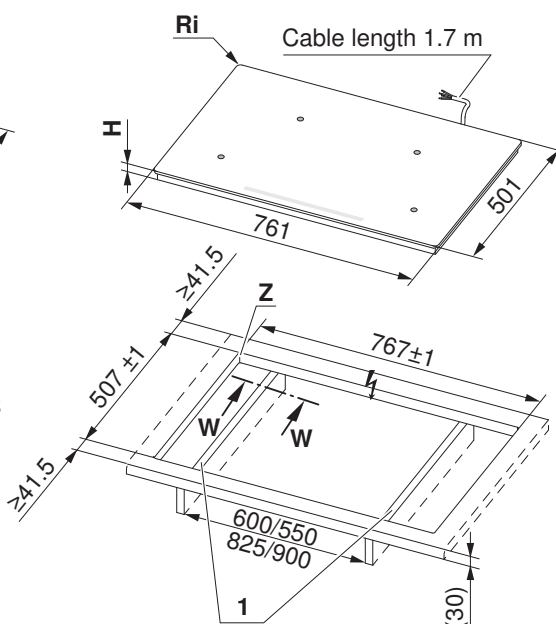
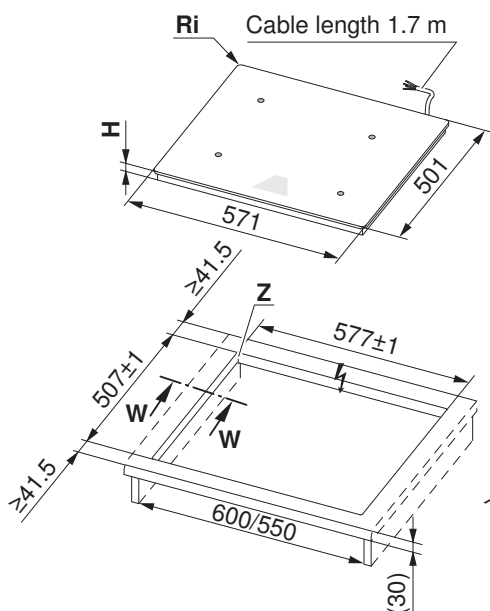

Steel angle mounted with adhesive or screws

Drawer/cabinet

* The clearance space must be maintained.

- 1 For symmetrical installation, it is not necessary to cut out the side walls.
- 2 Cut-outs in left/right side panels for a niche width of 900/825 mm, required for appliance ventilation. Keep the exhaust opening clear.

Type	A – loosely based on manufacturer	B	H	Corner radius Ra/Ri
GK36TIS.1F, GK46TIS.1F, GK46ID.1F, GK47IMDF, GK46TIMS.1F, GK47TIMSF/O, GK37TIMSF, GK46TIAS.1F, GK46TIABS.1F, GK46IABD.1F, GK47IMADF, GK46TIAKSF, GK46TIMASF, GK47TIMASF	≥30 mm	≥75 mm	51.7 mm	5/1.5 mm

- A** Worktop depth (in combination with directly built-under oven)
- B** Required clearance in the service exchange
- H** Measurement from the top side of the worktop to the underside of the hob (ventilation opening)
- Ri** Appliance corner radii
- Ra** External corner radii of the cut-out

Installation

1. Create the mounting cut-out accurately.
 - The mounting surface can be recessed by installing wood or stone bars or produced using the steel angle set (see Accessories).

Access to the appliance from below must be guaranteed over the entire cut-out surface. For service purposes, the induction generator can be removed from below with the bearing plate. It must be possible to unscrew the contact-proof covers from below.

2. Prepare the cut-out and appliance in accordance with the specifications in the enclosed cementing-in instruction.
3. Carefully cement the appliance in place and allow the silicon cement joints to dry for at least 24 hours.



4. Potentially connect to the electrical mains connection before inserting the appliance.

With oversize mounting frame

The cooking ring layout of the hob to be fitted can differ from the hob illustrated.

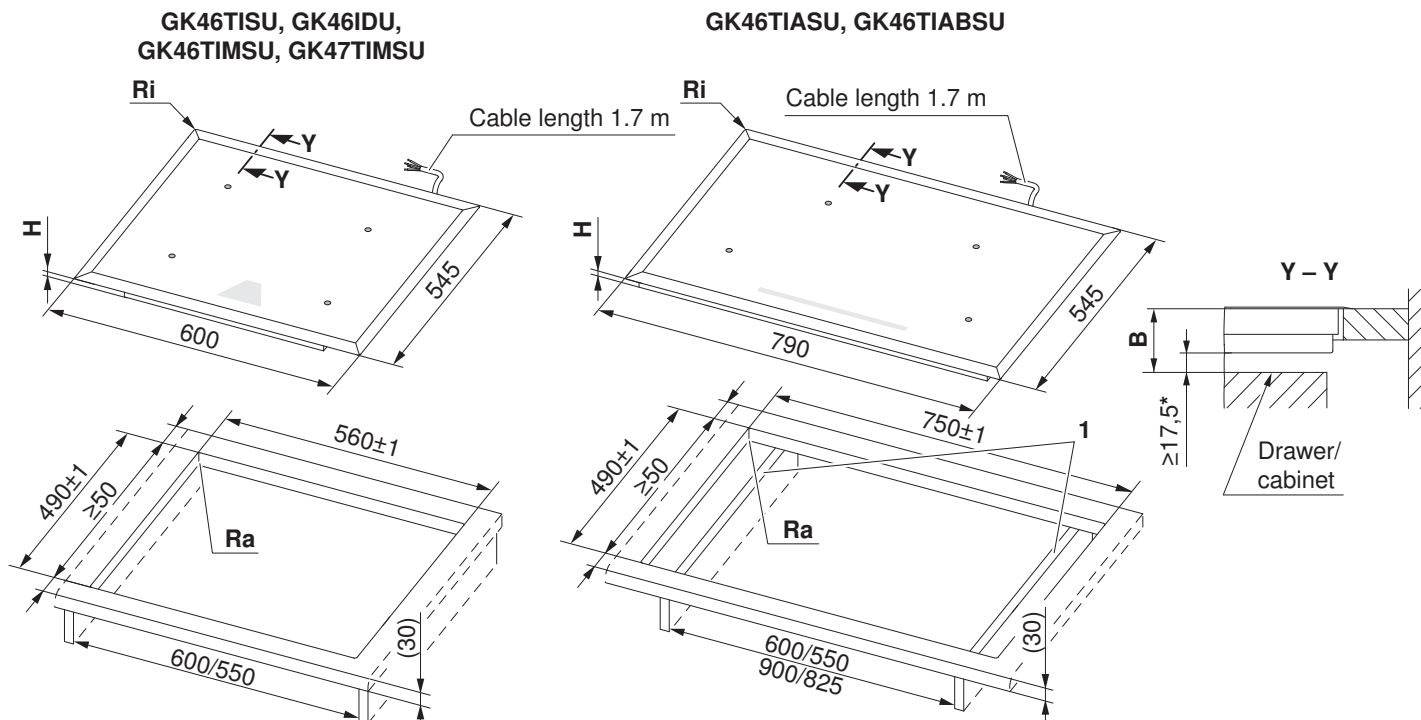

* The clearance space must be maintained.

Type	A – loosely based on manufacturer	B	H	Corner radius Ra/Ri
GK46TISU, GK46IDU, GK46TIMSU, GK47TIMSU	≥30 mm	≥58.2 mm	48.2 mm	10/8 mm
GK46TIASU, GK46TIABSU				

- A** Worktop depth (in combination with directly built-under oven)
- B** Required clearance in the service exchange
- H** Measurement from the top side of the worktop to the underside of the hob (ventilation opening)
- Ri** Appliance corner radii **Ra** External corner radii of the cut-out
- 1** For symmetrical installation, it is not necessary to cut out the side walls.
- 2** Cut-outs in left/right side panels for a niche width of 900/825 mm, required for appliance ventilation. Keep the exhaust opening clear.

Installation

1. Create the mounting cut-out accurately.
2. Carefully put the appliance in the installation cut-out and press against the worktop with sufficient overlap.

The appliances with oversize frames can also be used as an alternative to built-in solid plates and to installation in complete chrome-nickel steel covers. In the latter case, the built-in solid plate part is cut out of the chrome-nickel steel cover and replaced by an appliance (depth of the work surface ≥ 30 mm). In contrast to normal installation without a fastening system, the appliance is fixed from below using adjusting braces.



Variable areas of the special cut-out dimensions

GK46TIMSU, GK46TISU, GK46IDU, GK46TIMSU

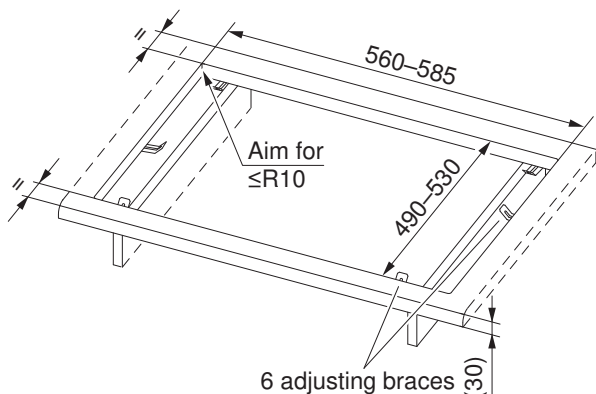

GK46TIASU, GK46TIABSU

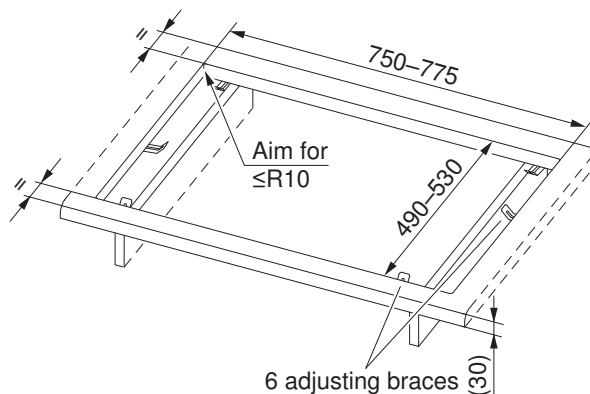

Reinforcement of the cut-outs with a complete chrome-nickel steel cover

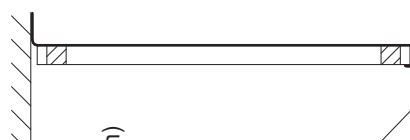
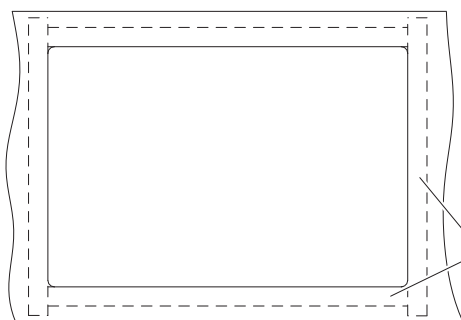
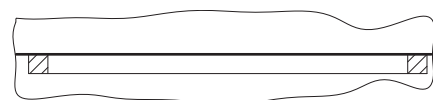

Reinforcing slats:
≥25 × 25 mm

Warning, glass breakage:
Do not overtighten screws

Arrangement of the adjusting braces

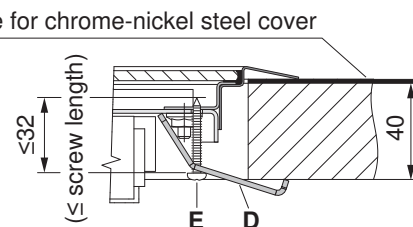

The installation instructions with regard to electrical and safety-related issues remain fully valid for this installation.

1. Make a precise, right-angled cut-out in the work surface (if not already present). Aim to keep the cut-out dimensions to a minimum.
2. Securely clamp the appliance in the cut-out using the enclosed adjusting braces **D** and screws **E**. If necessary, install reinforcing slats and use these to make the cover flat.

Installation of the ventilation protective plate with 3 mm ventilation gap at the front



A ventilation protective plate is required to ensure sufficient ventilation of the hob. There must be a distance of ≥ 10 mm between the underside of the appliance and the ventilation protective plate.



It is not possible to install a ventilation protective plate in the case of induction hobs with a dial control.

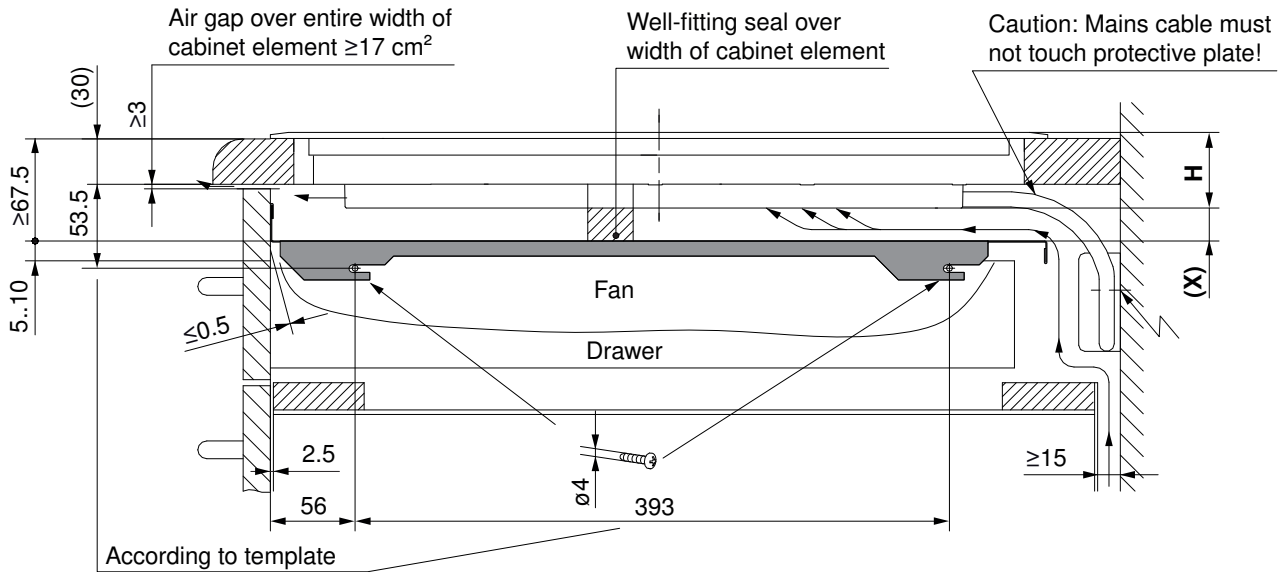

Type	X	Remarks
GK36TISC, GK46TISC, GK46TIABSC, GK46TIASC, GK46IDC, GK46IABDC, GK46TIMSC, GK46TIAKSC, GK46TIMASC, GK47TIMASC, GK47TIMSC/O, GK37TIMSC	12 mm	Normal mounting frame
GK36TIS, GK46TIS, GK46TIABS, GK46TIAS, GK46ID, GK46IABD, GK46TIMS, GK46TIAKS, GK46TIMAS, GK47TIMAS, GK47TIMS, GK37TIMS	14.3 mm	Frameless with bevels
GK36TIS.1F, GK46TIMS.1F, GK46TIS.1F, GK46TIABS.1F, GK46TIAS.1F, GK46ID.1F, GK46IABD.1F, GK47IMDF, GK47IMADF, GK46TIAKSF, GK46TIMASF, GK47TIMASF, GK47TIMSF/O, GK37TIMSF	10 mm	Frameless flush installation
GK46TISU, GK46TIABSU, GK46TIASU, GK46IDU, GK46TIMSU, GK47TIMSU	13 mm	With oversize mounting frame

H Dimension from the top of the work surface to the underside of the hob (fan opening).

Cool air supply with regard to drawer or cabinet installed below

To ensure good ventilation, there must be $\geq 10 \text{ mm}$ of space under the appliance.

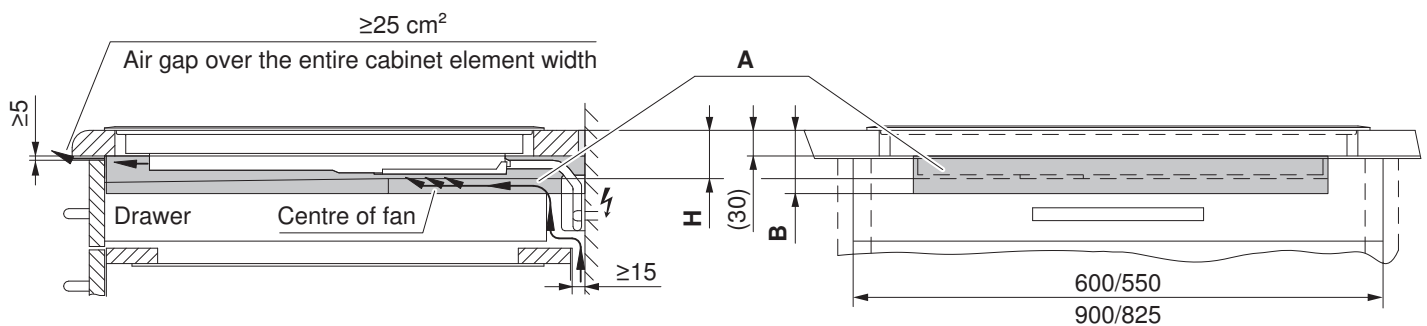

It is not possible to install a ventilation protective plate in the case of induction hobs with a dial control.

- A** Required space for the appliance under the work surface.
- B** Required space for the ventilation of the appliance under the work surface.
- H** Dimension from the top of the work surface to the underside of the hob (fan opening)